

# PMATH352W18 - Complex Analysis

CLASSNOTES FOR WINTER 2018

by

*Johnson Ng*

BMath (Hons), Pure Mathematics major, Actuarial Science Minor

University of Waterloo



## *Table of Contents*

<b>1</b>	<b>Lecture 1 Jan 3rd 2018</b>	<b>11</b>
1.1	Complex Numbers and Their Properties . . . . .	11
<b>2</b>	<b>Lecture 2 Jan 5th 2018</b>	<b>19</b>
2.1	Complex Numbers and Their Properties (Continued) . .	19
<b>3</b>	<b>Lecture 3 Jan 8th 2018</b>	<b>23</b>
3.1	Complex Numbers and Their Properties (Continued 2) .	23
3.1.1	Roots of Complex Numbers . . . . .	27
<b>4</b>	<b>Lecture 4 Jan 10th 2018</b>	<b>31</b>
4.1	Examples for nth Roots of Unity . . . . .	31
<b>5</b>	<b>Lecture 5 Jan 12 2018</b>	<b>37</b>
5.1	Complex Functions . . . . .	37
5.1.1	Limits . . . . .	37
5.1.2	Continuity . . . . .	39
<b>6</b>	<b>Lecture 6 Jan 15th 2018</b>	<b>41</b>
6.1	Continuity (Continued) . . . . .	41
6.2	Differentiability . . . . .	42
6.2.1	Cauchy-Riemann Equations . . . . .	44
<b>7</b>	<b>Lecture 7 Jan 17th 2018</b>	<b>47</b>
7.1	Differentiability (Continued) . . . . .	47
7.1.1	Cauchy-Riemann Equations (Continued) . . . . .	47
7.1.2	Power Series . . . . .	49
<b>8</b>	<b>Lecture 8 Jan 19 2018</b>	<b>51</b>
8.1	Power Series (Continued) . . . . .	51
8.1.1	Radius of Convergence . . . . .	51

<b>9</b>	<b>Lecture 9 Jan 22nd 2018</b>	<b>55</b>
9.1	Power Series (Continued 2) . . . . .	55
9.1.1	Radius of Convergence (Continued) . . . . .	55
<b>10</b>	<b>Lecture 10 Jan 24th 2018</b>	<b>59</b>
10.1	Power Series (Continued 3) . . . . .	59
10.1.1	Radius of Convergence (Continued 2) . . . . .	59
10.2	Integration in $\mathbb{C}$ . . . . .	60
10.2.1	Curves and Paths . . . . .	60
10.2.2	Integral . . . . .	62
<b>11</b>	<b>Lecture 11 Jan 26th 2018</b>	<b>65</b>
11.1	Integration in $\mathbb{C}$ (Continued) . . . . .	65
11.1.1	Integral (Continued) . . . . .	65
<b>12</b>	<b>Lecture 12 Jan 29th 2018</b>	<b>71</b>
12.1	Integration in $\mathbb{C}$ (Continued 2) . . . . .	71
12.1.1	Fundamental Theorem of Calculus . . . . .	71
	<b>Tutorial</b>	<b>75</b>
12.2	Practice Problems . . . . .	75
<b>13</b>	<b>Lecture 13 Feb 9th 2018</b>	<b>81</b>
13.1	Cauchy's Integral Formula . . . . .	81
<b>14</b>	<b>Lecture 14 Feb 12 2018</b>	<b>85</b>
14.1	Cauchy's Integral Formula (Continued) . . . . .	85
<b>15</b>	<b>Lecture 15 Feb 14th 2018</b>	<b>91</b>
15.1	Cauchy's Integral Formula (Continued 1) . . . . .	91
15.1.1	Applications of Cauchy's Integral Formula . . . . .	91
<b>16</b>	<b>Lecture 16 Feb 16th 2018</b>	<b>95</b>
16.1	Cauchy's Integral Formula (Continued 3) . . . . .	95
16.1.1	Applications of Cauchy's Integral Formula (Continued) . . . . .	95
<b>17</b>	<b>Lecture 17 Feb 26th 2018</b>	<b>99</b>
17.1	Analytic Continuity . . . . .	99
17.2	Morera's Theorem . . . . .	101
<b>18</b>	<b>Lecture 18 Feb 28th 2018</b>	<b>103</b>
18.1	Winding Numbers . . . . .	103

<b>19 Lecture 19 Mar 2nd 2018</b>	<b>107</b>
19.1 Singularities . . . . .	107
<b>20 Lecture 20 Mar 5th 2018</b>	<b>111</b>
20.1 Singularity (Continued) . . . . .	111
<b>21 Lecture 21 Mar 7th 2018</b>	<b>115</b>
21.1 Singularity (Continued 2) . . . . .	115
<b>22 Lecture 22 Mar 9th 2018</b>	<b>119</b>
22.1 Singularity (Continued 3) . . . . .	119
22.2 The Residue Theorem . . . . .	119
<b>23 Lecture 23 Mar 12th 2018</b>	<b>123</b>
23.1 The Residue Theorem (Continued) . . . . .	123
23.2 Applications of Cauchy's Residue Theorem . . . . .	126
<b>24 Lecture 24 Mar 14 2018</b>	<b>129</b>
24.1 Application of Cauchy's Residue Theorem (Continued) .	129
<b>25 Lecture 25 Mar 16 2018</b>	<b>135</b>
25.1 The Argument Principle . . . . .	135
<b>26 Lecture 26 Mar 19 2018</b>	<b>139</b>
26.1 The Argument Principle (Continued) . . . . .	139
26.1.1 Alternative Proof for FTA . . . . .	140
26.1.2 Open Mapping Theorem . . . . .	141
<b>27 Lecture 27 Mar 21 2018</b>	<b>143</b>
27.1 Introductory Passage to Log Functions in $\mathbb{C}$ . . . . .	143
27.2 Simply Connected Domains . . . . .	144
<b>28 Lecture 28 Mar 23 2018</b>	<b>147</b>
28.1 Constructing Logarithm . . . . .	147
28.2 Branches of the Logarithm . . . . .	149
<b>29 Lecture 29 Mar 26 2018</b>	<b>151</b>
29.1 Examples for Analytic Continuation . . . . .	151
29.2 Characterizing Logarithms . . . . .	153
<b>30 Lecture 30 Mar 28 2018</b>	<b>155</b>
30.1 Characterizing Logarithms . . . . .	155
30.2 Infinite Products . . . . .	156

<b>31</b>	<b>Lecture 31 Apr 02 2018</b>	<b>161</b>
31.1	Infinite Products (Continued) . . . . .	161
31.1.1	Application to Riemann Zeta Function . . . . .	162
<b>32</b>	<b>Lecture 32 Apr 04 2018</b>	<b>165</b>
32.1	Infinite Products (Continued 2) . . . . .	165
32.1.1	Weierstrass Products . . . . .	165
<b>33</b>	<b>Index</b>	<b>171</b>





















## *List of Definitions*

1	Complex Number, Complex Plane . . . . .	11
2	Sum and Product . . . . .	12
3	Conjugate . . . . .	14
4	Modulus . . . . .	15
5	Argument of a Complex Number . . . . .	23
6	Convergence . . . . .	37
7	Convergence for Complex Functions . . . . .	38
8	Continuity . . . . .	39
9	Neighbourhood . . . . .	42
10	Differentiable/Holomorphic . . . . .	42
11	Power Series . . . . .	49
12	Entire Function . . . . .	56
13	Curves in $\mathbb{C}$ . . . . .	61
14	Equivalent Parameterization . . . . .	61
15	Smooth Curve . . . . .	61
16	Piecewise Smooth . . . . .	62
17	Contour . . . . .	62
18	Closed Path . . . . .	72
19	Convex Set . . . . .	81
20	Analytic Functions . . . . .	91
21	Winding Numbers . . . . .	103





## *List of Theorems*

 Proposition 1	Basic Inequalities . . . . .	16
 Proposition 2	$n$ th Roots of a Complex Number . . . . .	27
 Theorem 3	Cauchy-Riemann Equations . . . . .	45
 Theorem 4	Conditional Converse of CRE . . . . .	48
 Theorem 5	Convergence in the Radius of Convergence	51
 Proposition 6	A Property of $\limsup$ . . . . .	52
 Theorem 7	Power function, holomorphic function, region of convergence . . . . .	52
 Corollary 8	Corollary of  Theorem 7 . . . . .	59
 Proposition 9	Properties of integrals in $\mathbb{C}$ . . . . .	66
 Theorem 10	Fundamental Theorem of Calculus . . . . .	71
 Corollary 11	Corollary of FTC . . . . .	72
 Theorem 12	Goursat's Theorem / Cauchy's Theorem for a triangle . . . . .	73
 Theorem 13	Cauchy's Theorem for Convex Set . . . . .	81
 Theorem 14	Cauchy's Integral Formula 1 . . . . .	82
 Lemma 15	. . . . .	85
 Proposition 16	Holomorphic Functions can be expressed as Power series . . . . .	87
 Theorem 17	Cauchy's Integral Formula 2 . . . . .	88
 Corollary 18	Taylor Expansion of Entire Functions . . . . .	89
 Lemma 19	Principle of Analytic Continuation . . . . .	94

 Corollary 21	Uniqueness of a Function . . . . .	100
 Theorem 22	Morera's Theorem . . . . .	101
 Theorem 23	Winding Number Theorem . . . . .	103
 Theorem 24	Theorem 9 . . . . .	109
 Theorem 25	Theorem 10 . . . . .	111
 Theorem 26	Theorem 9.1 . . . . .	113
 Theorem 27	Theorem 11 . . . . .	113
 Theorem 28	Casorati-Weierstrass . . . . .	115
 Corollary 29	. . . . .	119
 Theorem 30	Cauchy's Residue Theorem . . . . .	120
 Theorem 31	Cauchy's Residue Theorem - Generalized . . . . .	123
 Theorem 32	Argument Principle . . . . .	136
 Theorem 33	Rouché's Theorem . . . . .	137
 Corollary 34	. . . . .	141
 Theorem 35	Open Mapping Theorem . . . . .	141
 Theorem 36	Theorem 17 . . . . .	147
 Theorem 38	Theorem 18 . . . . .	155
 Lemma 39	Bounds of the Partial Product . . . . .	157
 Theorem 40	Theorem 19 . . . . .	158
 Corollary 41	Corollary for Theorem 19 . . . . .	163
 Theorem 42	Theorem 20 . . . . .	166
 Theorem 43	Theorem 21 . . . . .	167

# 1 Lecture 1 Jan 3rd 2018

## 1.1 Complex Numbers and Their Properties

---

### Definition 1 (Complex Number, Complex Plane)

A **complex number** is a vector in  $\mathbb{R}^2$ . The **complex plane**, denoted by  $\mathbb{C}$ , is a set of complex numbers,

$$\mathbb{C} = \mathbb{R}^2 = \left\{ \begin{pmatrix} x \\ y \end{pmatrix} : x, y \in \mathbb{R} \right\}$$

In  $\mathbb{C}$ , we usually write

$$\begin{aligned} 0 &= \begin{pmatrix} 0 \\ 0 \end{pmatrix} & 1 &= \begin{pmatrix} 1 \\ 0 \end{pmatrix} \\ i &= \begin{pmatrix} 0 \\ 1 \end{pmatrix} & x &= \begin{pmatrix} x \\ 0 \end{pmatrix} \\ iy &= \begin{pmatrix} 0 \\ y \end{pmatrix} \end{aligned}$$

where  $x, y \in \mathbb{R}$ . Consequently, we have that

$$x + iy = x + yi = \begin{pmatrix} x \\ y \end{pmatrix}$$

If for  $x, y \in \mathbb{R}$ ,  $z = x + iy$ , then  $x$  is called the **real part** of  $z$  and  $y$  is called the **imaginary part** of  $z$ , and we write

$$\operatorname{Re}(z) = x \quad \operatorname{Im}(z) = y.$$

---

---

### “ Note

- It is easy to see how  $\mathbb{R}$  is a subset of  $\mathbb{C}$ .
- Complex Numbers of the form  $\begin{pmatrix} 0 \\ y \end{pmatrix}$  where  $y \in \mathbb{R}$  are called **purely imaginary numbers**.
- Certain authors may prefer to denote  $i = \begin{pmatrix} 0 \\ 1 \end{pmatrix}$ .

### Definition 2 (Sum and Product)

We define the sum of two complex numbers to be the usual vector sum, i.e.

$$\begin{aligned} (a + ib) + (c + id) &= \begin{pmatrix} a \\ b \end{pmatrix} + \begin{pmatrix} c \\ d \end{pmatrix} \\ &= \begin{pmatrix} a + c \\ b + d \end{pmatrix} \\ &= (a + c) + i(b + d) \end{aligned}$$

where  $a, b, c, d \in \mathbb{R}$ .

We define the product of two complex numbers by setting  $i^2 = -1$ , and by requiring the product to be **commutative, associative, and distributive** over the sum. In this setup, we have that

$$\begin{aligned} (a + ib)(c + id) &= ac + iad + ibc + i^2bd \\ &= (ac - bd) + i(ad + bc) \end{aligned} \tag{1.1}$$

### “ Note

It is interesting to note that **any complex number times zero is zero**, just like what we have with real numbers.

$$\begin{aligned} \forall z = x + iy \in \mathbb{C} \quad x, y \in \mathbb{R} \quad 0 \in \mathbb{C} \\ z \cdot 0 = (x + iy)(0 + i0) = 0 + i0 = 0 \end{aligned}$$

### Example 1.1.1

Let  $z = 2 + i, w = 1 + 3i$ . Find  $z + w$  and  $zw$ .

$$\begin{aligned} z + w &= (2 + i) + (1 + 3i) \\ &= 3 + 4i \end{aligned}$$

$$\begin{aligned} zw &= (2 + i)(1 + 3i) \\ &= (2 - 3) + i(6 + 1) \quad \text{By Equation (1.1)} \\ &= -1 + 7i \end{aligned}$$

### Example 1.1.2

Show that every non-zero complex number has a **multiplicative inverse**,  $z^{-1}$ , and find a formula for this inverse.

Let  $z = a + ib$  where  $a, b \in \mathbb{R}$  with  $a^2 + b^2 \neq 0$ . Then

$$\begin{aligned} z(x + iy) &= 1 \\ \iff (ax - by) + i(ay + bx) &= 1 \\ \iff \begin{pmatrix} ax - by \\ ay + bx \end{pmatrix} &= \begin{pmatrix} 1 \\ 0 \end{pmatrix} \\ \iff \begin{pmatrix} a & -b \\ b & a \end{pmatrix} \begin{pmatrix} x \\ y \end{pmatrix} &= \begin{pmatrix} 1 \\ 0 \end{pmatrix} \\ \iff \begin{pmatrix} x \\ y \end{pmatrix} &= \frac{1}{a^2 + b^2} \begin{pmatrix} a & b \\ -b & a \end{pmatrix} \begin{pmatrix} 1 \\ 0 \end{pmatrix} \\ \iff \begin{pmatrix} x \\ y \end{pmatrix} &= \frac{1}{a^2 + b^2} \begin{pmatrix} a \\ -b \end{pmatrix} \\ \iff x + iy &= \frac{a}{a^2 + b^2} - i \frac{b}{a^2 + b^2} \end{aligned}$$

Therefore, we have that the formula for the inverse is

$$(a + ib)^{-1} = \frac{a}{a^2 + b^2} - i \frac{b}{a^2 + b^2} \quad (1.2)$$

### Notation

For  $z, w \in \mathbb{C}$ , we write

$$\begin{aligned} -z &= -1z & w - z &= w + (-z) \\ \frac{1}{z} &= z^{-1} & \frac{w}{z} &= wz^{-1} \end{aligned}$$

**Example 1.1.3**

Find  $\frac{(4-i)-(1-2i)}{1+2i}$ .

$$\begin{aligned}\frac{(4-i)-(1-2i)}{1+2i} &= \frac{3+i}{1+2i} \\ &= (3+i)\left(\frac{1}{5} - i\frac{2}{5}\right) \\ &= 1 - i\end{aligned}$$

**“ Note**

The set of complex numbers is a **field** under the operations of addition and multiplication. This means that  $\forall u, v, w \in \mathbb{C}$ ,

$$\begin{aligned}u + v &= v + u & uv &= vu \\ (u + v) + w &= u + (v + w) & (uv)w &= u(vw) \\ 0 + u &= u & 1u &= u \\ u + (-u) &= 0 & uu^{-1} &= 1, \quad u \neq 0 \\ u(v + w) &= uv + uw\end{aligned}$$

Since the distributive law holds for complex numbers, note that the **binomial expansion works** for  $(w + z)^n$  where  $w, z \in \mathbb{C}$  and  $n \in \mathbb{N}$ . (I did not verify if this is still true for when  $n \in \mathbb{R}$ .)

**Definition 3 (Conjugate)**

If  $z = x + iy$  where  $x, y \in \mathbb{R}$ , then the **conjugate of  $z$**  is given by  $\bar{z} = x - iy$

**Example 1.1.4**

Let  $z = 3 + 4i$ . Then the  $\bar{z} = 3 - 4i$ . Represented in the complex plane, we have the following:

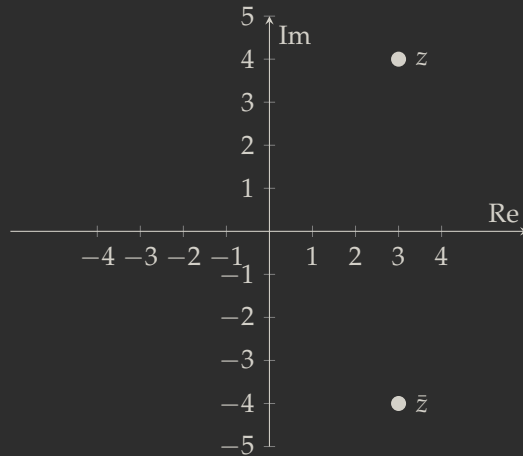

We observe that on the complex plane, the conjugate of a complex number is simply its reflection on the real axis.

---

#### Definition 4 (Modulus)

We define the **modulus** (length, magnitude) of  $z = x + iy \in \mathbb{C}, x, y \in \mathbb{R}$ , to be

$$|z| = \sqrt{x^2 + y^2} \in \mathbb{R}. \quad (1.3)$$

---

#### “ Note

Note that this definition is consistent with the notion of the absolute value in real numbers when  $z$  is a real number, since if  $y = 0$ ,  $|z| = |x + i0| = \sqrt{x^2} = \pm x$ .

---

#### “ Note

For  $z, w \in \mathbb{C}$  and  $n \in \mathbb{N}$ , we have

$$\begin{array}{lll} \bar{\bar{z}} = z & z + \bar{z} = 2 \operatorname{Re}(z) & z - \bar{z} = 2i \operatorname{Im}(z) \\ z\bar{z} = |z|^2 & |z| = |\bar{z}| & \overline{z \pm w} = \bar{z} \pm \bar{w} \\ \overline{z\bar{w}} = \bar{z}w & |zw| = |z| |w| & \bar{z}^n = \overline{z^n} \end{array}$$

but note that  $|z + w| \neq |z| + |w|$ .

Also, note that the last equation is a generalization of the **highlighted equation**.

**“ Note**

While inequalities such as  $z_1 < z_2$ , where  $z_1, z_2 \in \mathbb{C}$ , are meaningless unless if both of them are real,  $|z_1| < |z_2|$  means that the point  $z_1$  in the complex plane is closer to the origin than the point  $z_2$ .

**♦ Proposition 1 (Basic Inequalities)**

1.  $|\operatorname{Re}(z)| \leq |z|$
2.  $|\operatorname{Im}(z)| \leq |z|$
3.  $|z + w| \leq |z| + |w|$  *Triangle Inequality*
4.  $|z + w| \geq ||z| - |w||$  *Inverse Triangle Inequality*

**✎ Proof**

Note that  $|z|^2 = \operatorname{Re}(z)^2 + \operatorname{Im}(z)^2$  and that we can express  $|x| = \sqrt{x^2}$  for any  $x \in \mathbb{R}$ . 1 and 2 immediately follows from that.

To prove 3, we have that

$$\begin{aligned}
 |z + w|^2 &= (z + w)(\bar{z} + \bar{w}) \\
 &= |z|^2 + |w|^2 + (w\bar{z} + \bar{w}z) \\
 &= |z|^2 + |w|^2 + 2\operatorname{Re}(w\bar{z}) \\
 &\leq |z|^2 + |w|^2 + 2|w\bar{z}| \quad \text{by 1} \\
 &= |z|^2 + |w|^2 + 2|wz| \quad \text{since } |w\bar{z}| = |w||\bar{z}| \text{ and } |z| = |\bar{z}| \\
 &= (|z| + |w|)^2
 \end{aligned}$$

To prove 4, note that

$$|z| = |z + w - w| \leq |z + w| + |w| \quad (1.4)$$

$$|w| = |w + z - z| \leq |z + w| + |z| \quad (1.5)$$



Observe that

$$\text{Equation (1.4)} \implies |z| - |w| \leq |z + w|$$

$$\text{Equation (1.5)} \implies |w| - |z| \leq |z + w|$$

Thus, we have that

$$|z + w| \geq ||z| - |w||$$

as required.  $\square$

Item 3 in  $\spadesuit$  Proposition 1 can be generalized by the means of mathematical induction to sums involving any finite number of terms, as:

$$|z_1 + z_2 + \dots + z_n| \leq |z_1| + |z_2| + \dots + |z_n| \quad (1.6)$$

where  $n \in \mathbb{N} \setminus \{0, 1\}$ .

To note the induction proof, when  $n = 2$ , Equation (1.6) is just Item 3. If Equation (1.6) is true for when  $n = m$  where  $m \in \mathbb{N} \setminus \{0, 1\}$ ,  $n = m + 1$  is also true since by Item 3,

$$\begin{aligned} |(z_1 + z_2 + \dots + z_m) + z_{m+1}| &\leq |z_1 + z_2 + \dots + z_m| + |z_{m+1}| \\ &\leq (|z_1| + |z_2| + \dots + |z_m|) + |z_{m+1}|. \end{aligned}$$

The distance between two points  $z_1 = x_1 + iy_1, z_2 = x_2 + iy_2 \in \mathbb{C}$ ,  $x_1, x_2, y_1, y_2 \in \mathbb{R}$  is  $|z_1 - z_2|$ , since  $|z_1 - z_2| = \sqrt{(x_1 - x_2)^2 + (y_1 - y_2)^2}$  is our usual notion of the Euclidean distance of two points on a plane.

Also, note that

$$z_1 - z_2 = z_1 + (-z_2)$$

and thus if we apply our knowledge of vector representation,  $z_1 - z_2$  is the directed line segment from the point  $z_2$  to  $z_1$ .

With the notion of a “distance” set on the complex plane, we can now explore upon points lying on a circle with a center  $z_0$  and radius  $R$ , which satisfies the equation

$$|z - z_0| = R.$$

We may simply refer to this set of points as the circle  $|z - z_0| = R$ .

**Example 1.1.5**

We may describe a set  $\{z \in \mathbb{C} : |z - i| = 1\}$  as follows:

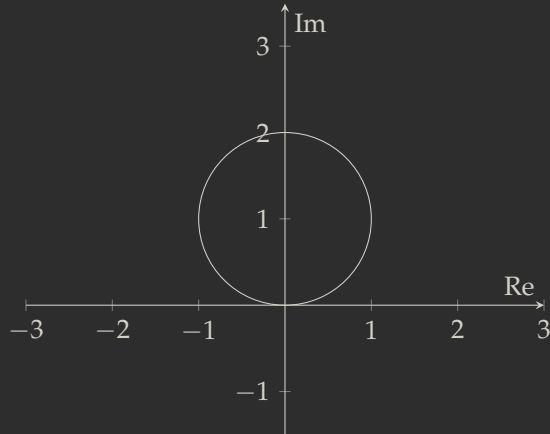

Let  $a, b \in \mathbb{C}$  describe the set  $\{z \in \mathbb{C} : |z - a| < |z - b|\}$ .

Suppose the following coordinates for  $a$  and  $b$  are arbitrary,

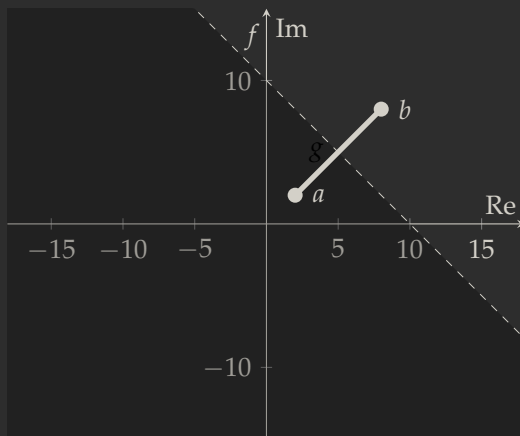

In the above,  $g$  is the line segment that connects the points  $a$  and  $b$  on the complex plane, while  $f$  is the perpendicular bisector of the line segment  $g$ . The area described by the set  $\{z \in \mathbb{C} : |z - a| < |z - b|\}$  is the shaded area which is below  $f$ .

## 2 Lecture 2 Jan 5th 2018

### 2.1 Complex Numbers and Their Properties (Continued)

#### Example 2.1.1

Let  $a \in \mathbb{C}$ . Describe the set  $\{z \in \mathbb{C} : 1 < |z - a| < 2\}$ .

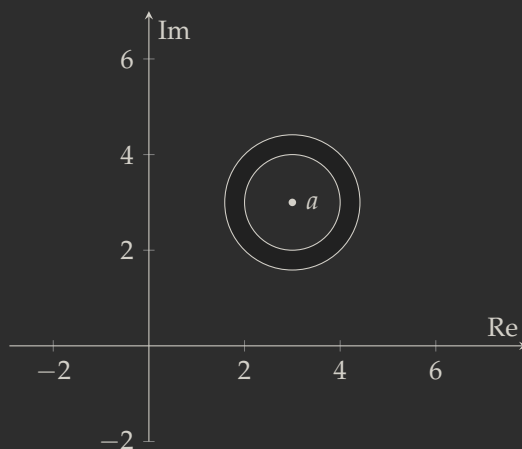

#### Example 2.1.2

Show that every non-zero complex number has exactly two complex square roots, and find a formula for the square roots.

Let  $z = x + iy \in \mathbb{C}$ ,  $x, y \in \mathbb{R}$ , and let  $w = u + iv$ ,  $u, v \in \mathbb{R}$ . Then

$$\begin{aligned}w^2 = z &\iff (u + iv)^2 = x + iy \\&\iff (u^2 - v^2) + i(2uv) = x + iy \\&\iff x = u^2 + v^2 \quad \text{and} \qquad (2.1)\end{aligned}$$

$$y = 2uv \qquad (2.2)$$

Square both sides of Equation (2.2), and thus we have  $y^2 = 4u^2v^2$ .

Multiply Equation (2.1) by  $4u^2$ , and we get

$$\begin{aligned} 4u^2x &= 4u^4 - 4u^2v^2 = 4u^4 - y^2 \\ \iff 0 &= 4u^4 - 4u^2x - y^2 \\ \iff u^2 &= \frac{4x \pm \sqrt{16x^2 + 16y^2}}{8} \\ &= \frac{x \pm \sqrt{x^2 + y^2}}{2} \end{aligned}$$

Suppose  $y \neq 0$ . Note that  $x < \sqrt{x^2 + y^2}$ . Thus  $u^2 = \frac{x + \sqrt{x^2 + y^2}}{2} \implies$   
 $u = \left( \frac{x + \sqrt{x^2 + y^2}}{2} \right)^{\frac{1}{2}}$ .

Similarly, we can get

$$v = \pm \left( \frac{-x + \sqrt{x^2 + y^2}}{2} \right)^{\frac{1}{2}}$$

Note that all four choices of signs satisfy Equation (2.1). If  $y > 0$ , then  $u$  and  $v$  are either both positive or both negative by Equation (2.2).

Suppose  $y = 0$ . Then we have

$$w^2 = z = x$$

Therefore, we get

$$w = \begin{cases} \pm \left[ \left( \frac{x + \sqrt{x^2 + y^2}}{2} \right)^{\frac{1}{2}} + i \left( \frac{-x + \sqrt{x^2 + y^2}}{2} \right)^{\frac{1}{2}} \right] & y > 0 \\ \pm \left[ \left( \frac{x + \sqrt{x^2 + y^2}}{2} \right)^{\frac{1}{2}} - i \left( \frac{-x + \sqrt{x^2 + y^2}}{2} \right)^{\frac{1}{2}} \right] & y < 0 \\ \pm \sqrt{x} & y = 0, x > 0 \\ \pm i\sqrt{x} & y = 0, x < 0 \end{cases}$$

### Remark

Let  $z \in \mathbb{C}$ . The notation  $\sqrt{z}$  may represent either one of the square roots of  $z$  or both of the square roots, i.e. **it is possible that  $\sqrt{z}$  represents a set.**

### Exercise 2.1.1

Is it always okay for complex numbers such that  $\sqrt{zw} = \sqrt{z}\sqrt{w}$ , for

$z, w \in \mathbb{C}$ ?

No. For example, consider  $z = w = -1$ . Then we have

$$\sqrt{zw} = \sqrt{1} = \pm 1$$

while

$$\sqrt{z}\sqrt{w} = i \cdot i = -1$$

and thus

$$\sqrt{zw} \neq \sqrt{z}\sqrt{w}.$$

### Example 2.1.3

Find the values of  $\sqrt{3 - 4i}$ .

By Example 2.1.2,

$$\begin{aligned} \sqrt{3 - 4i} &= \pm \left( \sqrt{\frac{3 + \sqrt{9 + 16}}{2}} - i \sqrt{\frac{-3 + \sqrt{9 + 16}}{2}} \right) \\ &= \pm(2 - i) \end{aligned}$$

### Remark

The quadratic formula holds for complex polynomials, i.e.

$$\forall a, b, c \in \mathbb{C} \quad a \neq 0 \quad \forall z \in \mathbb{C} \quad az^2 + bz + c = 0,$$

the solution for  $z$  is given by

$$z_{1,2} = \frac{-b \pm \sqrt{b^2 - 4ac}}{2a} \quad (2.3)$$

The following is a short proof.

---

 **Proof**

$$\begin{aligned}
az^2 + bz + c = 0 &\iff z^2 + \frac{b}{a}z + \frac{c}{a} = 0 \\
&\iff z^2 + \frac{b}{a}z + \left(\frac{b}{2a}\right)^2 - \left(\frac{b}{2a}\right)^2 + \frac{c}{a} = 0 \\
&\iff \left(z + \frac{b}{2a}\right)^2 = \frac{b^2}{4a^2} - \frac{c}{a} = \frac{b^2 - 4ac}{4a^2} \\
&\iff z = \frac{-b + \sqrt{b^2 - 4ac}}{2a}
\end{aligned}$$

---

(Personal Note: where did the  $-$  for the supposed  $\pm$  go? Or should it really be  $\pm$ ?)

**Example 2.1.4**

Solve  $iz^2 - (2 + 3i)z + 5(1 + i) = 0$ .

$$\begin{aligned}
z &= \frac{2 + 3i + \sqrt{(2 + 3i)^2 - 4i[5(1 + i)]}}{2i} \\
&= \frac{2 + 3i + \sqrt{-5 + 12i - 20i + 20}}{2i} \\
&= \frac{2 + 3i + \sqrt{15 + 8i}}{2i}
\end{aligned}$$

Note that by Example 2.1.2,

$$\begin{aligned}
\sqrt{15 + 8i} &= \pm \left[ \sqrt{\frac{15 + \sqrt{225 + 64}}{2}} - i \sqrt{\frac{-15 + \sqrt{225 + 64}}{2}} \right] \\
&= \pm \left[ \sqrt{\frac{15 + 17}{2}} - i \sqrt{\frac{-15 + 17}{2}} \right] \\
&= \pm(4 - i)
\end{aligned}$$

Thus we have

$$\begin{aligned}
z &= \frac{2 + 3i + \sqrt{15 + 8i}}{2i} \\
&= \frac{2 + 3i \pm (4 - i)}{2i} \\
&= (6 + 2i) \left(-\frac{1}{2}i\right) \text{ or } (-2 + 4i) \left(-\frac{1}{2}i\right) \quad \text{by Example 1.1.2} \\
&= (1 - 3i) \text{ or } (2 + i)
\end{aligned}$$

## 3 Lecture 3 Jan 8th 2018

### 3.1 Complex Numbers and Their Properties (Continued 2)

---

#### Definition 5 (Argument of a Complex Number)

Let  $z \in \mathbb{C} \setminus \{0\}$ . The **argument** (or the angle) of  $z$ , denoted by  $\arg z$ ,  $\text{Arg } z$ , or simply  $\theta = \theta(z)$ , is the angle modulo  $2\pi$  (i.e.  $0 \leq \theta < 2\pi$ ) between the vector defining  $z$  and the positive real axis (in the counter-clockwise direction).

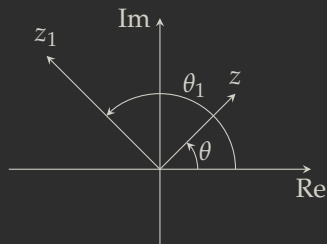

---

#### Notation

Let  $e^{i\theta} := \cos \theta + i \sin \theta$ . Note that this definition, called **Euler's formula**, can be derived by extending the Taylor expansion of  $e^x = \sum_{n=0}^{\infty} \frac{x^n}{n!}$  for when  $x \in \mathbb{C}$  (the sum of the real parts of the expansion is the Taylor expansion of cosine while the imaginary part for sine).

Now  $e^{i\theta}$  is on the unit circle.

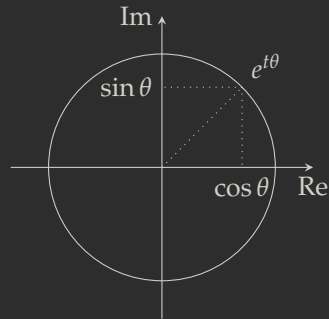
**Remark**

If  $z = 0$ , the coordinate  $\theta$  is undefined, and so it is implied that  $z \neq 0$  whenever we use the polar form.

**Example 3.1.1**

Some examples of  $\theta \in [0, 2\pi)$ :

$$\begin{aligned} e^{i\frac{\pi}{4}} &= \frac{\sqrt{2}}{2} + i\frac{\sqrt{2}}{2} & e^{i\frac{\pi}{2}} &= i \\ e^{i\frac{3\pi}{4}} &= -\frac{\sqrt{2}}{2} + i\frac{\sqrt{2}}{2} & e^{i\pi} + 1 &= 0 \end{aligned}$$

**Remark**

$$\forall k \in \mathbb{Z} \quad \forall \theta \in \mathbb{R} \quad e^{i\theta} = e^{i(\theta + 2\pi k)}$$

**Remark**

The complex number  $re^{i\theta}$ , where  $r > 0, \theta \in [0, 2\pi)$ , represents the complex number with modulus  $r$  and argument  $\theta$ .

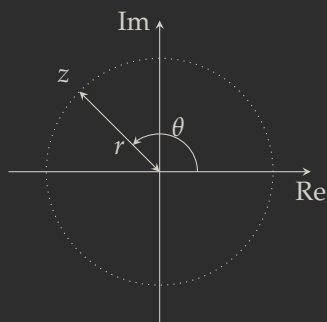

Therefore,  $\forall z \in \mathbb{C}$ , we can express

$$z := |z| e^{i \operatorname{Arg} z}. \quad (3.1)$$

With that, we now have two representations of a complex number:



- **Cartesian representation:**  $z = x + iy$  where  $x = \operatorname{Re}(z)$  and  $y = \operatorname{Im}(z)$
- **Polar representation:**  $z = re^{i\theta}$  where  $r = |z|$  and  $\theta = \operatorname{Arg} z \in [0, 2\pi)$

To convert between the two representations, we have the following equations:

Polar  $\rightarrow$  Cartesian:

$$x = r \cos \theta \quad y = r \sin \theta \quad (3.2)$$

Cartesian  $\rightarrow$  Polar:

$$\begin{aligned} r &= |z| \\ x \neq 0 &\implies \tan \theta = \frac{y}{x} \\ x = 0 &\implies \theta = \frac{\pi}{2} \text{ or } \frac{3\pi}{2} \end{aligned} \quad (3.3)$$

On another note,

$$z = re^{i\theta} \implies \bar{z} = re^{-i\theta}$$

and

$$z \neq 0 \implies \frac{1}{z} = \frac{1}{r} e^{-i\theta} \quad (3.4)$$

**Remark**

$$\begin{aligned} \forall r_1, r_2 \in \mathbb{R} \quad \forall \theta_1, \theta_2 \in [0, 2\pi) \\ z_1 := r_1 e^{i\theta_1} \quad z_2 := r_2 e^{i\theta_2} \end{aligned}$$

Then

$$z_1 z_2 = r_1 r_2 e^{i\theta_1} e^{i\theta_2} = r_1 r_2 e^{i(\theta_1 + \theta_2)}$$

Note that  $e^{ix}e^{iy} = e^{i(x+y)}$  is true for all  $x, y \in \mathbb{R}$  since

$$\begin{aligned} e^{ix}e^{iy} &= (\cos x + i \sin x)(\cos y + i \sin y) \\ &= (\cos x \cos y - \sin x \sin y) + i(\cos x \sin y + \cos y \sin x) \\ &= \cos(x + y) + i \sin(x + y) \\ &= e^{i(x+y)}. \end{aligned}$$

Generalizing the above, we get that

$$\forall n \in \mathbb{Z} \quad z = (re^{in}) = r^n e^{in\theta} \quad (3.5)$$

which is commonly known as **deMoivre's Law**. Note that by simply generalizing the above, all we have is that  $n \in \mathbb{Z}^+$ . But by Equation (3.4), we can have that for  $n \in \mathbb{Z}^-$ , let  $m = -n$ , and thus

$$z^n = \left[ \frac{1}{r} e^{i(-\theta)} \right]^m = \left( \frac{1}{r} \right)^m e^{im(-\theta)} = \left( \frac{1}{r} \right)^{-n} e^{i(-n)(-\theta)} = r^n e^{i\theta}$$

This proves that deMoivre's Law also holds for when  $n \in \mathbb{Z}^-$ .

Observe that if  $r = 1$ , Equation (3.5) becomes

$$(e^{i\theta})^n = e^{in\theta} \quad \text{for all } n \in \mathbb{Z} \setminus \{0\} \quad (3.6)$$

When written in the form

$$(\cos \theta + i \sin \theta)^n = \cos n\theta + i \sin n\theta \quad (n \in \mathbb{Z} \setminus \{0\}) \quad (3.7)$$

this is known as **deMoivre's formula**.

### Example 3.1.2

Equation (3.7) with  $n = 2$  tells us that

$$(\cos \theta + i \sin \theta)^2 = \cos 2\theta + i \sin 2\theta$$

or we can express the equation as

$$\cos^2 \theta - \sin^2 \theta + i2 \sin \theta \cos \theta = \cos 2\theta + i \sin 2\theta$$

Equating real and imaginary parts, we have the familiar double angle trigonometric identities

$$\cos 2\theta = \cos^2 \theta - \sin^2 \theta, \quad \sin 2\theta = 2 \sin \theta \cos \theta.$$

## 3.1.1 Roots of Complex Numbers

---

**Proposition 2 (nth Roots of a Complex Number)**

$$\begin{aligned} \forall z = re^{i\theta} \in \mathbb{C} \quad r = |z| \in \mathbb{R} \quad \theta \in [0, 2\pi) \\ \exists w = se^{i\tau} \in \mathbb{C} \quad s \in \mathbb{R} \quad \tau \in [0, 2\pi) \\ \forall n \in \mathbb{Z} \\ w^n = (se^{i\tau})^n = z = re^{i\theta} \end{aligned}$$

The  $n$ th roots of  $z$  is described by the set

$$\left\{ r^{\frac{1}{n}} e^{i\left(\frac{\theta+2\pi k}{n}\right)} : k = 0, 1, \dots, n-1 \right\} \quad (3.8)$$

---

**Proof**

$$\begin{aligned} s^n = r &\iff s = r^{\frac{1}{n}} \\ e^{in\theta} = e^{i\tau} &\iff \theta = \frac{\tau + 2\pi k}{n} \end{aligned}$$

Therefore, the set that describes the  $n$ th roots of  $z$  is

$$\left\{ w = r^{\frac{1}{n}} e^{i\left(\frac{\theta+2\pi k}{n}\right)} : k = 0, 1, \dots, n-1 \right\}$$

---

**Remark (nth Roots of Unity)**

The  **$n$ th roots of unity** is a direct consequence of **Proposition 2** where we solve for the equation  $z^n = 1$  for any  $z \in \mathbb{C}, n \in \mathbb{Z}$ .

The set that describes the  $n$ th roots of unity is

$$\left\{ e^{i\theta} : \theta = \frac{2\pi k}{n}, k = 0, 1, \dots, n-1 \right\} \quad (3.9)$$

It is easy to see how the  $n$ th roots of unity **partitions the unit circle into  $n$  parts**.







## 4 Lecture 4 Jan 10th 2018

### 4.1 Examples for $n$ th Roots of Unity

Recall that the  $n$ th roots of unity are given by  $e^{i\frac{2\pi k}{n}}, k = 0, 1, \dots, n-1$ .

#### Exercise 4.1.1

Let  $z$  be any  $n$ th root of unity other than 1. Show that

$$z^{n-1} + z^{n-2} + \dots + z + 1 = 0 \quad (4.1)$$

---

#### Proof

By the Sum of Finite Geometric Terms,

$$z^{n-1} + z^{n-2} + \dots + z + 1 = \frac{1 - z^n}{1 - z}.$$

Since  $z^n = 1$ , RHS is thus zero, which in turn completes the proof.

---

As an aside, if we wish to remove the restriction that  $z$  can also be 1, we may consider that

$$z^n - 1 = (z - 1)(1 + z + \dots + z^{n-1})$$

Since  $z^n = 1$ , LHS is zero. Then either  $z = 1$  or  $(1 + z + \dots + z^{n-1}) = 0$ .

#### Exercise 4.1.2

Consider the  $n - 1$  diagonals of a regular  $n$ -gon, inscribed in a circle of radius 1, obtained by connecting one vertex on the  $n$ -gon to all its other





factorize Equation (4.3) into

$$P(z) = (z - z_2)(z - z_3) \dots (z - z_n)$$

Now let  $z = 1$  and take the modulus of  $P(z)$ , and we get Equation (4.2).

### Exercise 4.1.3

Let  $n \in \mathbb{N}$ . Show that  $\sum_{j=0}^n \binom{3n}{3j} = \frac{2^{3n} + 2(-1)^n}{3}$ .

#### Proof

Let  $\alpha = e^{i\frac{2\pi}{3}}$ . Then  $\alpha$  is a cubic root of unity, i.e.  $\alpha^3 = 1$ , and from Exercise 4.1.1,  $1 + \alpha + \alpha^2 = 0$ .

Consider

$$\begin{aligned} (1+1)^{3n} &= \binom{3n}{0} + \binom{3n}{1} + \binom{3n}{2} + \binom{3n}{3} + \binom{3n}{4} \\ &\quad + \binom{3n}{5} + \binom{3n}{6} + \dots + \binom{3n}{3n} \end{aligned} \quad (4.4)$$

$$\begin{aligned} (1+\alpha)^{3n} &= \binom{3n}{0} + \binom{3n}{1}\alpha + \binom{3n}{2}\alpha^2 + \binom{3n}{3} + \binom{3n}{4}\alpha \\ &\quad + \binom{3n}{5}\alpha^2 + \binom{3n}{6} + \dots + \binom{3n}{3n} \end{aligned} \quad (4.5)$$

$$\begin{aligned} (1+\alpha^2)^{3n} &= \binom{3n}{0} + \binom{3n}{1}\alpha^2 + \binom{3n}{2}\alpha + \binom{3n}{3} + \binom{3n}{4}\alpha^2 \\ &\quad + \binom{3n}{5}\alpha + \binom{3n}{6} + \dots + \binom{3n}{3n} \end{aligned} \quad (4.6)$$

Adding Equation (4.4), Equation (4.5) and Equation (4.6), we observe that the terms with coefficients  $\binom{3n}{k}$  where  $k$  is not a multiple of 3 sums to

o as given by  $1 + \alpha + \alpha^2 = 0$ , and therefore we obtain

$$\begin{aligned}
 2^{3n} + (1 + \alpha)^{3n} + (1 + \alpha^2)^{3n} &= 3 \sum_{j=0}^n \binom{3n}{3j} \\
 \frac{1}{3} \left[ 2^{3n} + (1 + \alpha)^{3n} + (1 + \alpha^2)^{3n} \right] &= \sum_{j=0}^n \binom{3n}{3j} \\
 \frac{1}{3} \left[ 2^{3n} + (-\alpha^2)^{3n} + (-\alpha)^{3n} \right] &= \sum_{j=0}^n \binom{3n}{3j} \quad \text{since } 1 + \alpha + \alpha^2 = 0 \\
 \frac{1}{3} \left[ 2^{3n} + (-1)^n + (-1)^n \right] &= \sum_{j=0}^n \binom{3n}{3j} \quad \text{since } \alpha^3 = 1 \\
 \frac{2^{3n} + 2(-1)^n}{3} &= \sum_{j=0}^n \binom{3n}{3j}
 \end{aligned}$$

as required.

#### Exercise 4.1.4

Note that we can define  $\text{Arg } z$  in any interval of length  $2\pi$ , i.e. it is not necessary that  $\text{Arg } z \in [0, 2\pi)$ .

For example, if we restrict  $\text{Arg } z \in [-\pi, \pi]$ , then we can write

$$\text{Arg} \left( -\frac{1}{\sqrt{2}} - \frac{1}{\sqrt{2}}i \right) = -\frac{3\pi}{4}$$

Let  $z$  be on the unit circle and  $\text{Arg } z \in [-\pi, \pi]$ . Suppose that  $z \notin \mathbb{R}$ , i.e.  $z \neq 1, z \neq -1$ . Show that

$$\text{Arg} \left( \frac{z-1}{z+1} \right) = \begin{cases} \frac{\pi}{2} & \text{Im } z > 0 \\ -\frac{\pi}{2} & \text{Im } z < 0 \end{cases}$$

#### Proof

Note that  $\forall w_1, w_2 \in \mathbb{C}$ , where  $\text{Arg } w_1 = \tau_1, \text{Arg } w_2 = \tau_2$  for  $\tau_1, \tau_2$  in the same  $2\pi$ -interval,

$$\text{Arg} \frac{w_1}{w_2} = \frac{e^{i\tau_1}}{e^{i\tau_2}} \equiv e^{i(\tau_1 - \tau_2)} = \text{Arg } w_1 - \text{Arg } w_2 \quad (4.7)$$

in modulo  $2\pi$ .

Suppose  $\text{Im } z > 0$ . Let  $\theta_1 = \text{Arg}(z-1)$  and  $\theta_2 = \text{Arg}(z+1)$ . Consider Figure 4.3. Note that since both  $\theta_1, \theta_2 \in [0, \pi]$ , we have that

$\theta_1 - \theta_2 \in [-\pi, \pi]$ , and thus Equation (4.7) holds true without the need of the condition of being in modulo  $2\pi$ . We observe that

$$\frac{\pi}{2} = \theta_2 + \pi - \theta_1$$

$$\theta_1 - \theta_2 = \frac{\pi}{2}$$

as desired.

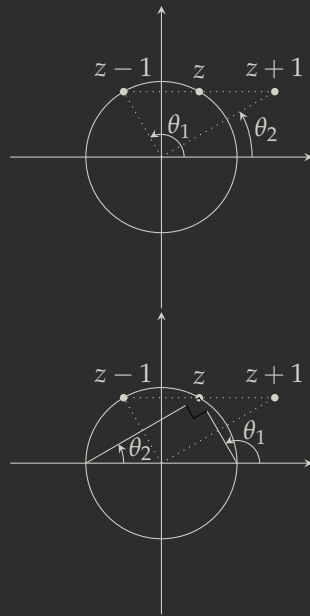

Figure 4.3: (Right) Depicted question, (Left) Translated Angles

Similarly, we can obtain  $\theta_1 - \theta_2 = -\frac{\pi}{2}$  for when  $\text{Im} z < 0$ . This completes the proof.

**Exercise 4.1.5**

Let  $f(z) = e^z$  for  $z \in \mathbb{C}$ . Let  $A = \{z = x + iy \in \mathbb{C} : x \leq 1, y \in [0, \pi]\}$ . Describe the image of  $f(A)$ .

**Solution**

Firstly, note that

$$e^z = e^{x+iy}$$

$$e^x \in (0, e]$$

$$y \in [0, \pi]$$

It is clear that the image will be in on the positive side of the imaginary-axis. Also, since  $e^x \in (0, e]$ , we get the right graph represented in Fig-



## 5 Lecture 5 Jan 12 2018

### 5.1 Complex Functions

#### 5.1.1 Limits

---

#### Definition 6 (Convergence)

A sequence of complex numbers  $z_1, z_2, z_3, \dots$  *converges* to  $z \in \mathbb{C}$  if

$$\lim_{n \rightarrow \infty} |z_n - z| = 0 \quad (5.1)$$

or we may say

$$\forall \varepsilon > 0 \exists N \in \mathbb{N} \forall n > N |z_n - z| < \varepsilon \quad (5.2)$$

---

#### “ Note

If  $\{z_n\}_{n \in \mathbb{N}}$  converges to  $z$ , we may write  $\lim_{n \rightarrow \infty} z_n = z$  or  $z_n \rightarrow z$  (as  $n \rightarrow \infty$ ).

---

#### Example 5.1.1

For  $|z| > 1$ , does  $\{\frac{1}{z^n}\}_{n=1}^{\infty}$  converge? Explain.

** Solution**

We claim that the limit is 0. Since  $|z| > 1$ , we have that

$$\begin{aligned} \lim_{n \rightarrow \infty} \left| \frac{1}{z^n} - 0 \right| &= \lim_{n \rightarrow \infty} \left| \frac{1}{z} \right|^n \\ &= 0 \end{aligned}$$

Another way to prove this, since  $|z| > 1 \implies 0 < \left| \frac{1}{z} \right| < 1$ ,

$$\begin{aligned} \forall \varepsilon = \left| \frac{1}{z} \right| > 0 \\ \left| \frac{1}{z^n} - 0 \right| = \left| \frac{1}{z} \right|^n < \left| \frac{1}{z} \right| = \varepsilon \end{aligned}$$

** Definition 7 (Convergence for Complex Functions)**

$\forall \Omega \subseteq \mathbb{C}$ , let  $f : \Omega \rightarrow \mathbb{C}$ . We say that

$$\lim_{z \rightarrow z_0} f(z) = L \tag{5.3}$$

for some  $L \in \mathbb{C}$  if for every sequence  $\{z_n\}_n \subseteq \Omega$  (not including  $z_0$  if it is in  $\Omega$ ), we have that

$$z_n \rightarrow z_0 \implies f(z_n) \rightarrow L \tag{5.4}$$

Note that  $L$  need not be in  $\Omega$ .

**Example 5.1.2**

Let  $f(z) = \frac{\bar{z}}{z}, z \in \mathbb{C} \setminus \{0\}$ . Find  $\lim_{z \rightarrow 0} f(z)$ .

** Solution**

Suppose  $z = x \in \mathbb{R} \setminus \{0\}$ . Then  $f(z) = f(x) = \frac{x}{x} = 1$ .

Suppose  $z = iy, y \in \mathbb{R} \setminus \{0\}$ . Then  $f(z) = f(iy) = \frac{-iy}{iy} = -1$ .

Therefore, the limit  $\lim_{z \rightarrow 0} f(z)$  does not exist.

**Exercise 5.1.1**

Show that  $z_n \rightarrow z \iff \operatorname{Re}(z_n) \rightarrow \operatorname{Re}(z) \wedge \operatorname{Im}(z_n) \rightarrow \operatorname{Im}(z)$ .

(Hint:  $|\operatorname{Re}(z)|, |\operatorname{Im}(z)| \leq |z| \leq |\operatorname{Re}(z)| + |\operatorname{Im}(z)|$ )

** Solution**

Suppose  $z_n \rightarrow z$ . Then  $\forall \varepsilon_0 > 0 \exists N \in \mathbb{N} \forall n > N |z_n - z| < \varepsilon$ . Note once and for all that

$$\begin{aligned}\operatorname{Re}(z_n - z) &= \operatorname{Re}(z_n) - \operatorname{Re}(z) \\ \operatorname{Im}(z_n - z) &= \operatorname{Im}(z_n) - \operatorname{Im}(z).\end{aligned}$$

Thus

$$\begin{aligned}|\operatorname{Re}(z_n) - \operatorname{Re}(z)| &= |\operatorname{Re}(z_n - z)| \\ &\leq |z_n - z| < \varepsilon \\ |\operatorname{Im}(z_n) - \operatorname{Im}(z)| &= |\operatorname{Im}(z_n - z)| \\ &\leq |z_n - z| < \varepsilon\end{aligned}$$

For the other direction,

$$\begin{aligned}\forall \frac{\varepsilon}{2} > 0 \exists N_0 \in \mathbb{N} \forall n > N_0 |\operatorname{Re}(z_n) - \operatorname{Re}(z)| < \frac{\varepsilon}{2} \\ \forall \frac{\varepsilon}{2} > 0 \exists N_1 \in \mathbb{N} \forall n > N_1 |\operatorname{Im}(z_n) - \operatorname{Im}(z)| < \frac{\varepsilon}{2}.\end{aligned}$$

Therefore,

$$\begin{aligned}|z_n - z| &= |\operatorname{Re}(z_n) + \operatorname{Im}(z_n) - \operatorname{Re}(z) - \operatorname{Im}(z)| \\ &\leq |\operatorname{Re}(z_n) - \operatorname{Re}(z)| + |\operatorname{Im}(z_n) - \operatorname{Im}(z)| \\ &\leq \varepsilon\end{aligned}$$

□

### 5.1.2 Continuity

#### Definition 8 (Continuity)

$\forall \Omega \subseteq \mathbb{C}$ , let  $f : \Omega \rightarrow \mathbb{C}$ . We say that  $f$  is **continuous** at  $z_0 \in \Omega$  if

1.  $\forall \{z_n\}_{n \in \mathbb{N}}$   
 $z_n \rightarrow z_0 \implies f(z_n) \rightarrow f(z_0)$
2.  $\forall \varepsilon > 0 \exists \delta > 0$   
 $|z - z_0| < \delta \implies |f(z) - f(z_0)| < \varepsilon$

**Remark**

1.  $f$  is continuous on  $\Omega$  if it is continuous on every point in  $\Omega$ .
2. We may **split**  $f$  into its real and imaginary parts, i.e.

$$f(z) = f(x, y) = u(x, y) + iv(x, y) \quad (5.5)$$

where  $u, v : \mathbb{R}^2 \rightarrow \mathbb{R}$ .

**Example 5.1.3**

Let  $f : \mathbb{C} \rightarrow \mathbb{C}$  and for  $z \in \mathbb{C}$ ,  $f(z) = \frac{\bar{z}}{z}$ . To split  $f$  into real and imaginary parts:

$$\begin{aligned} f(z) &= \frac{\bar{z}}{z} \\ &= (x + iy) \left( \frac{x}{x^2 + y^2} - i \frac{y}{x^2 + y^2} \right) \\ &= \frac{x^2 - y^2}{x^2 + y^2} + i \frac{(-2xy)}{x^2 + y^2} \end{aligned}$$

and we get

$$\begin{aligned} u(x, y) &= \frac{x^2 - y^2}{x^2 + y^2} \\ v(x, y) &= -\frac{2xy}{x^2 + y^2} \end{aligned}$$



## 6 Lecture 6 Jan 15th 2018

### 6.1 Continuity (Continued)

#### Exercise 6.1.1

Let  $f : \Omega \rightarrow \mathbb{C}$ . Prove that  $f(z)$  is continuous at  $z_0 = x_0 + iy_0 \in \mathbb{C} \iff$  functions  $u, v : \mathbb{R}^2 \rightarrow \mathbb{R}$ , such that  $f(z) = u(x, y) + iv(x, y)$  are both continuous at  $(x_0, y_0)$ .

#### Solution

We shall first prove the forward direction. Suppose that  $f(z)$  is continuous at  $z_0 = x_0 + iy_0 \in \mathbb{C}$ . By  Definition 8,  $\forall \{z_n\}_{n \in \mathbb{N}} \subseteq \Omega, z_n \rightarrow z_0 \implies f(z_n) \rightarrow f(z_0)$ . By Exercise 5.1.1,

$$\begin{aligned} z_n \rightarrow z_0 &\iff \operatorname{Re} z_n \rightarrow \operatorname{Re} z_0 \wedge \operatorname{Im} z_n \rightarrow \operatorname{Im} z_0 \\ &\iff x_n \rightarrow x_0 \wedge y_n \rightarrow y_0 \end{aligned} \tag{6.1}$$

where  $z_n = x_n + iy_n$  for  $x_n, y_n \in \mathbb{R}$ .

Similarly so, and by Equation (5.5),

$$f(z_n) \rightarrow f(z_0) \iff u(x_n, y_n) \rightarrow u(x_0, y_0) \wedge v(x_n, y_n) \rightarrow v(x_0, y_0) \tag{6.2}$$

Putting together Equation (6.1) and Equation (6.2), we get

$$(x_n, y_n) \rightarrow (x_0, y_0) \implies u(x_n, y_n) \rightarrow u(x_0, y_0) \wedge v(x_n, y_n) \rightarrow v(x_0, y_0)$$

as desired.

The proof of the other direction is simply a reversed process of the above.

□

## 6.2 Differentiability

**Definition 9 (Neighbourhood)**

For  $z_0 \in \mathbb{C}, r \in \mathbb{R}$ , let

$$D(z_0, r) := \{z \in \mathbb{C} : |z - z_0| < r\}. \quad (6.3)$$

On the complex plane, this is seen as an open disk centered around the point  $z_0$  with radius  $r$ , as shown below. This open disk is called a **neigh-**

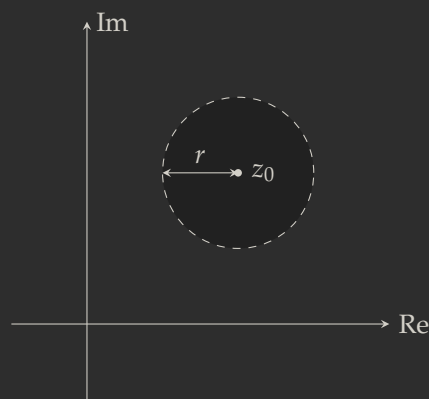

Figure 6.1: Open disk centered around  $z_0$  with radius  $r$

**bourhood** of  $z_0$ .

**Definition 10 (Differentiable/Holomorphic)**

Let  $f(z)$  be defined in a neighbourhood of  $z_0 \in \mathbb{C}$ . We say  $f$  is **differentiable/holomorphic** at  $z_0$  if for some  $h \in \mathbb{C}$ ,

$$\lim_{h \rightarrow 0} \frac{f(z_0 + h) - f(z_0)}{h} \quad (6.4)$$

exists. If such a limit exists, we denote the limit by  $f'(z_0)$ .

**Remark**

$h \in \mathbb{C}$  :  $h$  need not necessarily be real. In this sense,  $h$  approaches 0 from **any direction** around  $0 \in \mathbb{C}$ .

**Example 6.2.1**

For  $z \in \mathbb{C} \setminus \{0\}$ , let  $f(z) = \frac{1}{z}$ . Let  $z_0 \in \mathbb{C} \setminus \{0\}$ . Note that

$$\lim_{h \rightarrow 0} \frac{\frac{1}{z_0+h} - \frac{1}{z_0}}{h} = \lim_{h \rightarrow 0} \frac{1}{h} \left[ \frac{-h}{(z_0+h)z_0} \right] = -\frac{1}{z_0^2}$$

Thus  $f$  is holomorphic at any  $z \in \mathbb{C} \setminus \{0\}$ , and hence  $f'(z) = -\frac{1}{z^2}$ .

### Example 6.2.2

For  $z \in \mathbb{C}$ , let  $f(z) = \bar{z}$ . Let  $z_0 \in \mathbb{C}$ . Notice that

$$\lim_{h \rightarrow 0} \frac{\overline{z_0+h} - \bar{z}_0}{h} = \lim_{h \rightarrow 0} \frac{\bar{h}}{h}.$$

From Example 5.1.2, we know that such a limit does not exist. Thus  $f$  is not holomorphic on any  $z \in \mathbb{C}$ .

### Exercise 6.2.1 (Holomorphic Functions Properties)

If  $f, g$  are holomorphic at  $z \in \mathbb{C}$ , prove that

1.  $f + g$  is holomorphic and  $(f + g)' = f' + g'$ .
2.  $fg$  is holomorphic and  $(fg)' = f'g + fg'$ .
3. if  $g(z) \neq 0$ ,  $\frac{f}{g}$  is holomorphic and  $\left(\frac{f}{g}\right)' = \frac{f'g - fg'}{g^2}$ .

#### Solution

1. For  $f + g$ ,

$$\begin{aligned} & \lim_{h \rightarrow 0} \frac{f(z+h) + g(z+h) - f(z) - g(z)}{h} \\ &= \lim_{h \rightarrow 0} \left[ \frac{f(z+h) - f(z)}{h} + \frac{g(z+h) - g(z)}{h} \right] \\ &= f'(z) + g'(z) \end{aligned}$$

Thus  $(f + g)' = f' + g'$ .

2. For  $fg$ ,

$$\begin{aligned} & \lim_{h \rightarrow 0} \frac{f(z+h)g(z+h) - f(z)g(z)}{h} \\ &= \lim_{h \rightarrow 0} \frac{f(z+h)g(z+h) + f(z)g(z+h) - f(z)g(z+h) - f(z)g(z)}{h} \\ &= \lim_{h \rightarrow 0} \left[ \frac{f(z+h) - f(z)}{h} g(z+h) + f(z) \frac{g(z+h) - g(z)}{h} \right] \\ &= f'(z)g(z) + f(z)g'(z) \end{aligned}$$

Therefore,  $(fg)' = f'g + fg'$ .

3. When  $\forall z \in \mathbb{C} \ g(z) \neq 0$ , for  $\frac{f}{g}$ ,

$$\begin{aligned} & \lim_{h \rightarrow 0} \frac{\frac{f(z+h)}{g(z+h)} - \frac{f(z)}{g(z)}}{h} \\ &= \lim_{h \rightarrow 0} \frac{1}{h} \left[ \frac{f(z+h)g(z) - f(z)g(z+h)}{g(z+h)g(z)} \right] \\ &= \lim_{h \rightarrow 0} \frac{1}{g(z+h)g(z)} \left[ \frac{f(z+h)g(z) + f(z)g(z) - f(z)g(z) - f(z)g(z+h)}{g} \right] \\ &= \lim_{h \rightarrow 0} \frac{1}{g(z+h)g(z)} \left[ \frac{[f(z+h) - f(z)]g(z) - f(z)[g(z+h) - g(z)]}{h} \right] \\ &= \frac{f'(z)g(z) - f(z)g'(z)}{g^2(z)} \end{aligned}$$

Hence,  $\frac{f}{g} = \frac{f'g - fg'}{g^2}$

### “ Note

If we look at the example above from the perspective of  $f$  being treated as a real-valued function, i.e.  $f(z) = u(x, y) + iv(x, y)$  where  $u, v : \mathbb{R}^2 \rightarrow \mathbb{R}$  and  $z = x + iy$ , observe that  $\forall (x, y) \in \mathbb{R}^2, (x, y) \mapsto (x, -y)$ , which we see that  $u$  and  $v$  are partially differentiable in  $\mathbb{R}^2$ .

We will now look into this “discrepancy”.

## 6.2.1 Cauchy-Riemann Equations

Consider the following function taken from Equation (6.4),

$$f'(z_0) = \lim_{h \rightarrow 0} \frac{f(z_0 + h) - f(z_0)}{h} \quad (6.5)$$

While  $h$  may approach  $0 \in \mathbb{C}$  from infinitely many sides on the complex plane, we will consider 2 cases.

Case 1:  $h \rightarrow 0$  via the real axis

In this case,  $h = x + i(0)$  and  $x \rightarrow 0 \in \mathbb{R}$ . Then Equation (6.5) gives

$$\begin{aligned} f'(z_0) &= \lim_{x \rightarrow 0} \frac{u(x_0 + x, y_0) + iv(x_0 + x, y_0) - u(x_0, y_0) - iv(x_0, y_0)}{x} \\ &= \lim_{x \rightarrow 0} \left[ \frac{u(x_0 + x, y_0) - u(x_0, y_0)}{x} + i \frac{v(x_0 + x, y_0) - v(x_0, y_0)}{x} \right] \\ &= \frac{\partial u}{\partial x} \Big|_{(x_0, y_0)} + i \frac{\partial v}{\partial x} \Big|_{(x_0, y_0)} \end{aligned} \quad (6.6)$$

Case 2:  $h \rightarrow 0$  via the imaginary axis

In this case,  $h = 0 + iy$  and  $y \rightarrow 0 \in \mathbb{R}$ . In a similar fashion, Equation (6.5) becomes

$$\begin{aligned} f'(z_0) &= \lim_{y \rightarrow 0} \left[ \frac{u(x_0, y_0 + y) - u(x_0, y_0)}{iy} + \frac{v(x_0, y_0 + y) - v(x_0, y_0)}{y} \right] \\ &= \frac{1}{i} \cdot \frac{\partial u}{\partial y} \Big|_{(x_0, y_0)} + \frac{\partial v}{\partial y} \Big|_{(x_0, y_0)} \end{aligned} \quad (6.7)$$

Note that since  $f'(z_0)$  exists, the real and imaginary part of Equation (6.6) and Equation (6.7) must equate. Also note that  $\frac{1}{i} = -i$ . With that, we obtain the following theorem.

---

**■ Theorem 3 (Cauchy-Riemann Equations)**

If  $f(z)$  is holomorphic at  $z_0 = x_0 + iy_0 \in \mathbb{C}$  where  $x_0, y_0 \in \mathbb{R}$ , then, at  $(x_0, y_0)$ ,

$$\frac{\partial u}{\partial x} = \frac{\partial v}{\partial y} \quad \text{and} \quad \frac{\partial v}{\partial x} = -\frac{\partial u}{\partial y}. \quad (6.8)$$



---



## 7 Lecture 7 Jan 17th 2018

### 7.1 Differentiability (Continued)

#### 7.1.1 Cauchy-Riemann Equations (Continued)

It is natural to wonder if the **converse** of  Theorem 3 is true. We present the following example.

#### Example 7.1.1

Let

$$f(z) = \begin{cases} \frac{\bar{z}^2}{z} & \text{if } z \neq 0 \\ 0 & \text{if } z = 0 \end{cases}$$

Check if

1.  $f$  is holomorphic at 0.
2.  Theorem 3 holds at  $(0, 0)$ .

---

#### Proof

1. Observe that by letting  $h = x_h + iy_h$  where  $x_h, y_h \in \mathbb{R}$ ,

$$\lim_{h \rightarrow 0} \frac{\overline{0+h^2} - 0}{0+h} = \lim_{h \rightarrow 0} \frac{\bar{h}^2}{h} = \lim_{x_h + iy_h \rightarrow 0} \left( \frac{x_h - iy_h}{x_h + iy_h} \right)^2$$

Consider  $y_h = kx_h$ , for  $k \in \mathbb{R} \setminus \{0\}$ . Then

$$\lim_{x_h \rightarrow 0} \left( \frac{x_h - ikx_h}{x_h + ikx_h} \right)^2 = \left( \frac{1 - ik}{1 + ik} \right)^2,$$

where we see that the limit depends on the value of  $k$ . Therefore, the limit DNE. Hence  $f$  is not holomorphic at 0.

2. Let  $z = x + iy$  for  $x, y \in \mathbb{R}$ . Then

$$\frac{\bar{z}^2}{z} = \frac{(x - iy)^2}{x + iy} = \frac{(x - iy)^3}{x^2 + y^2} = \frac{x^3 - 3xy^2}{x^2 + y^2} + i \frac{(-3x^2y + y^3)}{x^2 + y^2}$$

Therefore, we obtain

$$u(x, y) = \begin{cases} \frac{x^3 - 3xy^2}{x^2 + y^2} & (x, y) \neq (0, 0) \\ 0 & (x, y) = (0, 0) \end{cases}$$

$$v(x, y) = \begin{cases} \frac{y^3 - 3x^2y}{x^2 + y^2} & (x, y) \neq (0, 0) \\ 0 & (x, y) = (0, 0) \end{cases}$$

Observe that

$$\left. \frac{\partial u}{\partial x} \right|_{(0,0)} = \lim_{x \rightarrow 0} \frac{u(x, 0) - u(0, 0)}{x} = 1$$

$$\left. \frac{\partial v}{\partial y} \right|_{(0,0)} = \lim_{y \rightarrow 0} \frac{v(0, y) - v(0, 0)}{y} = 1$$

and

$$\left. \frac{\partial u}{\partial y} \right|_{(0,0)} = \lim_{y \rightarrow 0} \frac{u(0, y) - u(0, 0)}{y} = 0$$

$$\left. \frac{\partial v}{\partial x} \right|_{(0,0)} = \lim_{x \rightarrow 0} \frac{v(x, 0) - v(0, 0)}{x} = 0$$

satisfies Equation (6.8).

This illustrates that the converse of  Theorem 3 is not true. We will, however, show that the converse will be true given an extra condition.

#### Theorem 4 (Conditional Converse of CRE)

Let  $z_0 = x_0 + iy_0 \in \Omega \subseteq \mathbb{C}$ ,  $x_0, y_0 \in \mathbb{R}$ , and  $u, v : \mathbb{R}^2 \rightarrow \mathbb{R}$ ,  $f = u + iv : \Omega \rightarrow \mathbb{C}$ . If

1. the partials of  $u, v$  exist in a neighbourhood of  $(x_0, y_0)$ ,
2. the partials of  $u, v$  are continuous at  $(x_0, y_0)$ , and
3.  $\frac{\partial u}{\partial x} = \frac{\partial v}{\partial y}$  and  $\frac{\partial v}{\partial x} = -\frac{\partial u}{\partial y}$  at  $(x_0, y_0)$ ,

then  $f$  is holomorphic at  $z_0$ .



A proof of the theorem is in page 36 of Newman and Bak (recommended text of PMATH352W18). I may include the proof whenever I am free.

### 7.1.2 Power Series

#### Definition 11 (Power Series)

A *power series* in  $\mathbb{C}$  is an infinite series of the form

$$\sum_{n \in \mathbb{N}} c_n z^n, \quad (7.1)$$

where each  $c_n \in \mathbb{C}$  is the coefficient of  $z$  of the  $n$ -th power.

In this subsection, we are interested to see if Equation (7.1) converges.

Recall the notion of convergence in series from  $\mathbb{R}$ . Equation (7.1) converges if the sequence of partial sums  $\{S_N\}$  converges as  $N \rightarrow \infty$ , where

$$S_N := \sum_{n=0}^N c_n z^n$$

In other words, using the same definition of  $S_N$ ,

$$\begin{aligned} \forall \varepsilon > 0 \quad \exists N \in \mathbb{N} \setminus \{0\} \quad \forall n > N \\ |S_n - L| < \varepsilon \end{aligned}$$

where  $L \in \mathbb{C}$  is the limit that the sequence converges to.

We also know that Equation (7.1) converges absolutely if  $\sum_{n=0}^{\infty} |c_n| |z|^n$  converges. This is a stronger statement (i.e. absolute convergence  $\implies$  convergence)

$$\therefore \left| \sum_{n=0}^N c_n z^n \right| \leq \sum_{n=0}^N |c_n| |z|^n \quad \text{for each } N \in \mathbb{N}$$

#### Example 7.1.2

$\sum_{n=0}^{\infty} z^n$  converges absolutely for  $|z| < 1$ .

Note that the partial sum of a geometric series is

$$\sum_{n=0}^N r^n = \frac{1 - r^{N+1}}{1 - r}$$

and so the limit as  $N \rightarrow \infty$  exists if  $|r| < 1$ , and hence we see that

$$\sum_{n=0}^N r^n \rightarrow \frac{1}{1 - r}$$

if  $|r| < 1$  as  $N \rightarrow \infty$ .

However, if  $|z| = 1$ , the power series diverges.

Another note that we shall point out is that if Equation (7.1) converges absolutely for some  $z_0 \in \mathbb{C}$ , then it converges absolutely for any  $z$  where  $|z| < |z_0|$ .

These notions, in turn, begs the question of **what is the largest possible  $|z_0|$  for the series to converge absolutely.**

## 8 Lecture 8 Jan 19 2018

### 8.1 Power Series (Continued)

#### 8.1.1 Radius of Convergence

---

#### Theorem 5 (Convergence in the Radius of Convergence)

For any power series  $\sum_{n \in \mathbb{N}} c_n z^n$ ,  $\exists 0 \leq R < \infty$ , such that

1.  $|z| < R \implies$  series converges absolutely.
2.  $|z| > R \implies$  series diverges.

Moreover,  $R$  is given by **Hadamard's Formula**:

$$\frac{1}{R} := \limsup_{n \rightarrow \infty} |c_n|^{\frac{1}{n}} \quad (8.1)$$

---

#### Remark

1.  $R$  is called the **radius of convergence** of the series.  $\{z \in \mathbb{C} : |z| < R\}$  is called the **disk of convergence** of the series.
2. Recall the definition of the **limit supremum**

$$\limsup_{n \rightarrow \infty} a_n := \lim_{n \rightarrow \infty} (\sup_{m \geq n} a_m) \quad (8.2)$$

which we may colloquially say as the "highest peak 'reached' by  $a_n$ 's as  $n \rightarrow \infty$ "

---

#### Proposition 6 (A Property of limsup)

$$\begin{aligned} \forall \{a_n\}_{n \in \mathbb{N}} \quad L := \limsup_{n \rightarrow \infty} a_n &\implies \\ \forall \varepsilon > 0 \quad \exists N > 0 \quad \forall n > N & \\ L - \varepsilon < a_n < L + \varepsilon & \end{aligned}$$

(Proof to be included)

 **Proof (📖 Theorem 5)**

Let  $L := \frac{1}{R} = \limsup_{n \rightarrow \infty} |c_n|^{\frac{1}{n}}$ . Clearly,  $L \geq 0$ .

1. Suppose  $|z| < R$ .  $\exists \varepsilon > 0, r := |z|(L + \varepsilon)$  such that  $0 < r < 1$ . By  Proposition 6,  $\exists N \in \mathbb{N}, \forall n > N, |c_n|^{\frac{1}{n}} < L + \varepsilon$ .

Now since  $L = \frac{1}{R}$ ,

$$\sum_{n=N}^{\infty} |c_n| |z|^n = \sum_{n=N}^{\infty} (|c_n|^{\frac{1}{n}} |z|)^n < \sum_{n=N}^{\infty} r^n$$

and since  $0 < r < 1$ , the final summation converges (as it is a geometric sum). Thus by comparison test,  $\sum_{n=N}^{\infty} |c_n| |z|^n$  converges.

We may also proceed with noticing that the partial sum of  $\sum_{n=N}^{\infty} |c_n| |z|^n$  is **bounded and monotonic**, which shows that the series converges.

2. Suppose  $|z| > R$ .  $\exists \varepsilon > 0, r := |z|(L - \varepsilon)$  such that  $r > 1$ . By  Proposition 6,  $\exists N \in \mathbb{N}, \forall n > N, |c_n|^{\frac{1}{n}} > L - \varepsilon$ . Then analogous to the proof above,

$$\sum_{n=N}^{\infty} |c_n| |z|^n = \sum_{n=N}^{\infty} (|c_n|^{\frac{1}{n}} |z|)^n > \sum_{n=N}^{\infty} r^n$$

where the final summation diverges, and thus implying that  $\sum_{n=N}^{\infty} |c_n| |z|^n$  diverges.

 **Theorem 7 (Power function, holomorphic function, region of convergence)**

Suppose  $f(z) = \sum_{n \in \mathbb{N}} c_n z^n$  has a radius of convergence  $R \in \mathbb{R}$ . Then



For the second term, since  $a^2 - b^2 = (a - b)(a^{n-1} + a^{n-2}b + \dots + ab^{n-2} + b^{n-1})$  and  $|z_0|, |z_0 + h| < r \leq R$ , we obtain  $(z_0 + h)^n - z_0^n \leq hnr^{n-1}$ .

Thus

$$\left| \frac{E_N(z_0 + h) - E_N(z_0)}{h} \right| = \left| \frac{1}{h} \sum_{n=N+1}^{\infty} c_n [(z_0 + h)^n - z_0^n] \right| \leq \sum_{n=N+1}^{\infty} nc_n r^{n-1}.$$

Note that

$$\sum_{n=1}^{\infty} nc_n r^{n-1} = g(r), \quad (8.4)$$

and since  $r < R$ , Equation (8.4) converges absolutely by  Theorem 5, thus the tail  $\sum_{n=N+1}^{\infty} nc_n r^{n-1}$  converges absolutely. Therefore, by comparison, we can pick  $\frac{\varepsilon}{3} > 0$  so that  $\exists N_1 \in \mathbb{N}, \forall n > N_1$

$$\left| \frac{E_N(z_0 + h) - E_N(z_0)}{h} \right| < \frac{\varepsilon}{3}.$$

For the third term in Equation (8.3), we observe that by definition,  $S'_N(z_0) = \sum_{n=1}^N nc_n z_0^{n-1}$ . Since

$$\lim_{N \rightarrow \infty} S'_N(z_0) = \lim_{N \rightarrow \infty} \sum_{n=1}^N nc_n z_0^{n-1} = \sum_{n=1}^{\infty} nc_n z_0^{n-1} = g(z_0)$$

we know that we can pick  $\frac{\varepsilon}{3} > 0, \exists N_2 \in \mathbb{N}, \forall n > N_2$ , we have

$$|S'_N(z_0) - g(z_0)| < \frac{\varepsilon}{3}$$

For the first term in Equation (8.3), note that  $(S_N(z_0))' = S'_N(z_0)$ . Let  $\frac{\varepsilon}{3} > 0, \exists \delta > 0, \exists N > \max\{N_1, N_2\}, \forall n > N$ , since  $|h| < \delta$ , we have that

$$\left| \frac{S_N(z_0 + h) - S_N(z_0)}{h} - S'_N(z_0) \right| < \frac{\varepsilon}{3}$$

This completes the proof. □

---

## 9 Lecture 9 Jan 22nd 2018

### 9.1 Power Series (Continued 2)

#### 9.1.1 Radius of Convergence (Continued)

##### Example 9.1.1

Let  $f(z) = \sum_{n=1}^{\infty} \frac{z^n}{n}$ . To find the radius of convergence, we use Hadamard's Formula:

$$\frac{1}{R} = \limsup_{n \rightarrow \infty} \left( \frac{1}{n} \right)^{\frac{1}{n}} = 1 \quad \because \lim_{n \rightarrow \infty} n^{\frac{1}{n}} = 1$$

Therefore  $R = 1$ . Thus, by  Theorem 5,  $f$  converges absolutely when  $|z| < 1$  and diverges when  $|z| > 1$ . As for the boundary, i.e.  $|z| = 1$ , consider the following two cases:

1. If  $z = 1$ , then  $f(1) = \sum_{n=1}^{\infty} \frac{1}{n}$  is a **harmonic series**, and hence  $f$  diverges.
2. If  $z = i$ , then

$$\begin{aligned} f(i) &= \sum_{n=1}^{\infty} \frac{i^n}{n} \\ &= i - \frac{1}{2} + \frac{-i}{3} + \frac{1}{4} + \frac{i}{5} - \frac{1}{6} \\ &= \left( -\frac{1}{2} + \frac{1}{4} - \frac{1}{6} + \dots \right) + i \left( 1 - \frac{1}{3} + \frac{1}{5} + \dots \right). \end{aligned}$$

Observe that both the real and imaginary parts are alternating series where the absolute values of each term is decreasing, which, by the **alternating series test**, converge. Thus in this case,  $f$  converges.

Therefore, we observe that **both convergence and divergence may occur** on the boundary, depending on the value of  $z$ .

**Note**

We may not always exchange the position of  $\lim$  and  $\sum_{a=1}^b$  when we consider an infinite sum (i.e.  $b = \infty$ ). Here's an example why this is true. Consider the function  $f(x) = \sum_{n=1}^{\infty} (x^n - x^{n-1})$  for  $|x| < 1$ . Is

$$\lim_{x \rightarrow 1} \sum_{n=1}^{\infty} (x^n - x^{n-1}) = \sum_{n=1}^{\infty} \lim_{x \rightarrow 1} (x^n - x^{n-1})$$

true?

Clearly, RHS is 0. For LHS, note that

$$\begin{aligned} f(x) &= \lim_{N \rightarrow \infty} \sum_{n=1}^N (x^n - x^{n+1}) \\ &= \lim_{N \rightarrow \infty} (x - x^2 + x^2 - x^3 + \dots + x^N - x^{N+1}) \\ &= \lim_{N \rightarrow \infty} (x - x^{N+1}) = x. \end{aligned}$$

So,

$$\text{LHS} = \lim_{x \rightarrow 1} x = 1$$

And we see that  $\text{RHS} \neq \text{LHS}$ .

**Definition 12 (Entire Function)**

A function  $f$  is said to be **entire** if  $f$  is holomorphic in **the entire complex plane**.

**Exercise 9.1.1**

Define  $e^z = \sum_{n=0}^{\infty} \frac{z^n}{n!}$ . Show that

1. the radius of convergence of this series is  $\infty$ , and hence that  $e^z$  is an entire function. (Hint: Use **Stirling's formula**:  $n! \sim \left(\frac{n}{e}\right)^n \sqrt{2\pi n}$ )
2.  $(e^z)' = e^z$

**Solution**

1. Using Stirling's formula, note that we have

$$e^z = \sum_{n=0}^{\infty} \frac{1}{\sqrt{2\pi n}} \left(\frac{ez}{n}\right)^n$$



To find  $R$ , we have

$$\begin{aligned} \frac{1}{R} &= \limsup_{n \rightarrow \infty} \left| \frac{1}{\sqrt{2\pi n}} \left(\frac{e}{n}\right)^n \right|^{\frac{1}{n}} \\ &= \limsup_{n \rightarrow \infty} \left| \frac{e}{n} \right| \limsup_{n \rightarrow \infty} \left| \frac{1}{\sqrt{2\pi n}} \right|^{\frac{1}{n}} \\ &= 0 \end{aligned}$$

since  $\limsup_{n \rightarrow \infty} \frac{e}{n} = 0$  and  $\limsup_{n \rightarrow \infty} \left| \frac{1}{\sqrt{2\pi n}} \right|^{\frac{1}{n}} = 1$ . Thus  $R = \infty$ .  
By  Theorem 5,  $e^z$  is an entire function.

2. Note that

$$\begin{aligned} \lim_{h \rightarrow 0} \frac{e^{z+h} - e^z}{h} &= e^z \lim_{h \rightarrow 0} \frac{e^h - 1}{h} \\ &= e^z \lim_{h \rightarrow 0} \frac{1 + h + \frac{h^2}{2} + \frac{h^3}{3} + \dots - 1}{h} \\ &= e^z \end{aligned}$$

Thus  $(e^z)' = e^z$  as required.



## 10 Lecture 10 Jan 24th 2018

### 10.1 Power Series (Continued 3)

#### 10.1.1 Radius of Convergence (Continued 2)

A power series is infinitely  $\mathbb{C}$ -differentiable in its radius of convergence. All its derivatives are also power series, obtained by term-wise differentiation.

E.g.

$$f(z) = \sum_{n=0}^{\infty} c_n z^n \quad \text{then} \quad f^{(2)}(z) = \sum_{n=0}^{\infty} n(n-1)c_n z^{n-2}$$

In general, we may have  $\sum_{n=0}^{\infty} c_n (z - z_0)^n$ , which is a power series centered at  $z_0 \in \mathbb{C}$ . Then, as before, the radius of convergence of this power series is given by

$$\frac{1}{R} = \limsup_{n \rightarrow \infty} |c_n|^{\frac{1}{n}}$$

So instead of having the disc of convergence centered around 0, we now have one that is centered around  $z_0$ .

---

#### ✦ Corollary 8 (Corollary of Theorem 7)

From  Theorem 7, we have shown that

$f(z)$  has a power series expansion at  $z_0$  (i.e.

$f(z) = \sum_{n=0}^{\infty} c_n (z - z_0)^n$  in some neighbourhood of  $z_0$ ) with radius of convergence

$R > 0$

$\implies$

$f$  is holomorphic at  $z_0$

The converse of the statement above is true, i.e.

$$f \text{ is holomorphic at } z_0 \quad \implies \quad \begin{array}{l} f(z) \text{ has a power series expansion at } z_0 \text{ (i.e.} \\ f(z) = \sum_{n=0}^{\infty} c_n (z - z_0)^n \text{ in some} \\ \text{neighbourhood of } z_0) \text{ with radius of} \\ \text{convergence } R > 0 \end{array}$$

This converse, however, is not possible to be proven given the current tools on our belt. And so we now have to venture into integrals in  $\mathbb{C}$ .

## 10.2 Integration in $\mathbb{C}$

### 10.2.1 Curves and Paths

Before we begin with the definition of a curve in  $\mathbb{C}$ , let us consider how a straight line should be described as a vector-valued function in the complex plane. For instance, if we have two points  $\alpha, \beta \in \mathbb{C}$ , and we want to describe the straight line connecting the two.

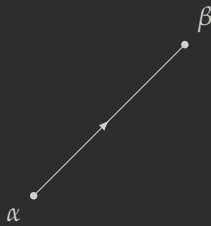

Let  $\gamma$  be the function that describes this line. We may then define  $\gamma : [0, 1] \rightarrow \mathbb{C}$  to be either

$$\gamma(t) = \alpha + (\beta - \alpha)t \quad \text{or} \quad \gamma = \alpha(1 - t) + \beta t.$$

We would then have the following mapping:

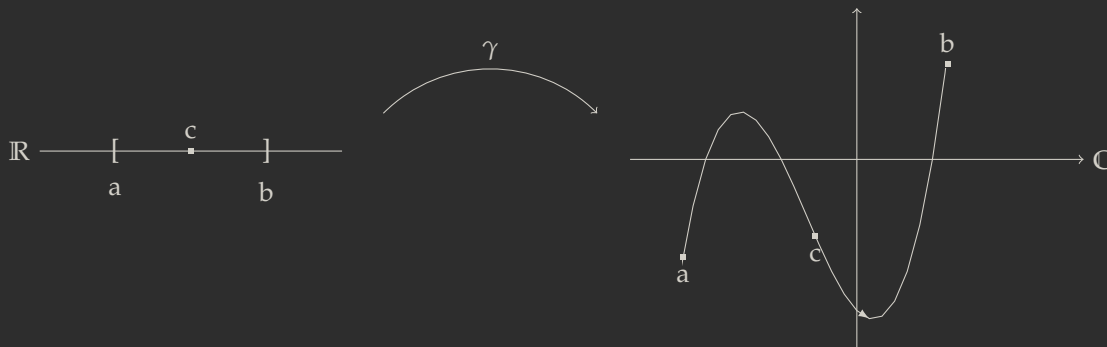

Figure 10.1: Mapping from  $\mathbb{R} \rightarrow \mathbb{C}$  with  $\gamma$ , which is called **the curve**  $\gamma$

**Definition 13 (Curves in  $\mathbb{C}$ )**

A curve in  $\mathbb{C}$  is a continuous function,  $\gamma(t) : [a, b] \rightarrow \mathbb{C}$ , where  $a, b \in \mathbb{R}$ . The image of  $\gamma$  in  $\mathbb{C}$  is called  $\gamma^*$ .

**Example 10.2.1**

Let  $z_0 \in \mathbb{C}, r > 0$ .

1. Let  $\gamma : [0, 2\pi] \rightarrow \mathbb{C}$ , such that  $\gamma(t) = z_0 + re^{it}$ .
  2. Let  $\gamma' : [0, 1] \rightarrow \mathbb{C}$ , such that  $\gamma'(t) = z_0 + re^{2\pi it}$ .
- The two functions above describe a circle centered at  $z_0$  with radius  $r$ , anticlockwise-oriented.

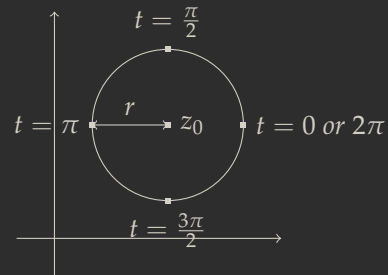

We say that  $\gamma$  and  $\gamma'$  are equivalent parameterizations for the same oriented path.

**Definition 14 (Equivalent Parameterization)**

Let  $\gamma_1 : [a, b] \rightarrow \mathbb{C}, \gamma_2 : [c, d] \rightarrow \mathbb{C}$  where  $a, b, c, d \in \mathbb{C}$  describe the path  $\gamma^*$ . The two parameterizations are said to be **equivalent parameterizations** if  $\exists h : [a, b] \rightarrow [c, d]$  that is a bijection and a continuous function such that

$$\gamma_1(t) = \gamma_2(h(t))$$

where  $t \in [a, b]$ .

**Note**

We will not look at functions like the Weierstrass function in this course.

**Definition 15 (Smooth Curve)**

Let  $\gamma : [a, b] \rightarrow \mathbb{C}, a, b \in \mathbb{C}$ .  $\gamma$  is said to be smooth if its derivative  $\gamma'$  exists and is continuous on  $[a, b]$  and  $\forall t \in [a, b], \gamma'(t) \neq 0$ .

**Definition 16 (Piecewise Smooth)**

Let  $\gamma : [a, b] \rightarrow \mathbb{C}$ .  $\gamma$  is said to be piecewise smooth if it is smooth on  $[a, b]$  except on finitely many points in  $[a, b]$ .

**Remark**

Piecewise smooth curves shall be called paths.

**10.2.2 Integral****Definition 17 (Contour)**

Given a path  $\gamma : [a, b] \rightarrow \mathbb{C}$  and  $f : \mathbb{C} \rightarrow \mathbb{C}$ , a function continuous on  $\gamma$ . We define the integral  $f$  along  $\gamma$ , called a **contour**, as

$$\int_{\gamma} f(z) dz := \int_a^b f(\gamma(t))\gamma'(t)dt \quad (10.1)$$

where we let  $z = \gamma(t)$  and hence  $dz = \gamma'(t)dt$ .

**Remark**

1. Suppose  $g$  is a complex-valued function, then

$$\int_a^b g(t)dt = \int_a^b \operatorname{Re}(g(t))dt + i \int_a^b \operatorname{Im}(g(t))dt$$

2. The integral of  $f$  along  $\gamma$  can be shown to be independent of the chosen parameterization for  $\gamma^*$ .

**Proof**

Let  $a, b, c, d \in \mathbb{R}$ ,  $\gamma_1 : [a, b] \rightarrow \mathbb{C}$ ,  $\gamma_2 : [c, d] \rightarrow \mathbb{C}$  describe the same path  $\gamma^*$ . By Definition 14, define a bijection  $h : [a, b] \rightarrow [c, d]$  that is a continuous function such that  $t \mapsto \tau$ , so that

$$\gamma_1(t) = \gamma_2(h(t)) = \gamma(\tau).$$

Note that

$$\begin{aligned}\gamma_1'(t) &= h'(t)\gamma_2'(h(t)) \text{ and} \\ h(t) = \tau &\implies h'(t)dt = d\tau.\end{aligned}$$

Now since  $h$  is a bijection, we claim that  $h(a) = c$  while  $h(b) = d$ .

We know that  $h$  cannot be a constant function. Suppose  $h$  is an increasing function, then since  $a \leq b$  and  $c \leq d$ , it is clear that  $h(a) = c$  and  $h(b) = d$ . Similarly, if  $h$  is a decreasing function, then  $h(a) = d$  and  $h(b) = c$ . But this is a contradiction to our supposition that  $\gamma_1$  and  $\gamma_2$  describe the same orientation. Thus  $h$  must be an increasing function, and hence we have  $h(a) = c$  and  $h(b) = d$ .

*(This can be more rigorous but that is an easy proof, and we may use perhaps the Approximation Property of  $\mathbb{R}$  to that end, which is a fun exercise that shall not be included within these covers.)*

Now

$$\begin{aligned}\int_{\gamma_1} f(z) dz &= \int_a^b f(\gamma_1(t))\gamma_1'(t)dt \\ &= \int_a^b f(\gamma_2(h(t)))h'(t)\gamma_2'(h(t))dt \\ &= \int_c^d f(\gamma_2(\tau))\gamma_2'(\tau)d\tau \\ &= \int_{\gamma_2} f(z) dz\end{aligned}$$

This completes the proof. □

---





## 11 Lecture 11 Jan 26th 2018

### 11.1 Integration in $\mathbb{C}$ (Continued)

#### 11.1.1 Integral (Continued)

---

##### “ Note (Recall)

Let  $\gamma : [a, b] \rightarrow \mathbb{C}$  be a piecewise smooth curve. For a function  $f$  that is continuous on  $\gamma$ , we defined

$$\begin{aligned}\int_{\gamma} f(z) dz &= \int_a^b f(\gamma(t)) \gamma'(t) dt \\ &= \int_a^b \operatorname{Re} \left( f(\gamma(t)) \gamma'(t) \right) dt + i \int_a^b \operatorname{Im} \left( f(\gamma(t)) \gamma'(t) \right) dt\end{aligned}$$

and have

$$\gamma'(t) = u'(t) + i v'(t)$$

$$\text{if } \gamma(t) = u(t) + i v(t)$$

---

##### Example 11.1.1

Let  $f(z) = f(x + iy) = x^2 + y^2$  be continuous along  $\gamma : [0, 1] \rightarrow \mathbb{C} \ t \mapsto t + it$ . Evaluate  $\int_{\gamma} f(z) dz$ .

 **Solution**

$$\begin{aligned}
\int_{\gamma} f(z) dz &= \int_0^1 f(t+it)(1+i) dt \\
&= (1+i)^2 \int_0^1 t^2 dt \\
&= (1+i)^2 \cdot \frac{1}{3} t^3 \Big|_0^1 \\
&= \frac{2i}{3}
\end{aligned}$$

**Example 11.1.2**

$\forall n \in \mathbb{Z}$ , evaluate  $\int_{\gamma} z^n dz$  that is continue on the path  $\gamma$  that describes any circle centered at origin oriented anticlockwise.

 **Solution**

Let  $R \in \mathbb{R}$ , and define

$$\begin{aligned}
\gamma : [0,1] &\rightarrow \mathbb{C} \quad t \mapsto Re^{2\pi it} \\
\gamma'(t) &= 2R\pi i e^{2\pi it} = 2\pi i \gamma(t)
\end{aligned}$$

Then

$$\begin{aligned}
\int_{\gamma} z^n dz &= \int_0^1 R^n e^{2\pi i n t} \cdot 2\pi i \cdot R e^{2\pi i t} dt \\
&= 2\pi i R^{n+1} \int_0^1 e^{2\pi i (n+1)t} dt \\
&= \begin{cases} \frac{R^{n+1}}{n+1} e^{2\pi i (n+1)t} \Big|_0^1 & \text{if } n \in \mathbb{Z} \setminus \{-1\} \\ 2\pi i t \Big|_0^1 & \text{if } n = -1 \end{cases} \\
&= \begin{cases} \frac{R^{n+1}}{n+1} (e^{2\pi i (n+1)} - 1) & \text{if } n \in \mathbb{Z} \setminus \{-1\} \\ 2\pi i & \text{if } n = -1 \end{cases} \quad \because e^{2\pi ki} \equiv 1 \pmod{2\pi} \\
&= \begin{cases} 0 & \text{if } n \in \mathbb{Z} \setminus \{-1\} \\ 2\pi i & \text{if } n = -1 \end{cases}
\end{aligned}$$

Note that our final answer does not depend on  $R$ , the radius of the circle.

 **Proposition 9 (Properties of integrals in  $\mathbb{C}$ )**

- (Linearity)** Let  $\alpha, \beta \in \mathbb{C}$ .  $\int_{\gamma} (\alpha f(z) + \beta g(z)) dz = \alpha \int_{\gamma} f(z) dz + \beta \int_{\gamma} g(z) dz$ .





We are now in a position to generalize the **Fundamental Theorem of Calculus** for  $\mathbb{C}$ .



## 12 Lecture 12 Jan 29th 2018

### 12.1 Integration in $\mathbb{C}$ (Continued 2)

#### 12.1.1 Fundamental Theorem of Calculus

To simplify statements from hereon, we shall use the following notations.

---

##### Notation

Let  $\Omega \subseteq \mathbb{C}$  be an open set in  $\mathbb{C}$ . We denote  $f \in H(\Omega) \iff f$  is holomorphic on  $\Omega$ .

---

##### Theorem 10 (Fundamental Theorem of Calculus)

Let  $\gamma : [a, b] \rightarrow \mathbb{C}$  be a path inside an open set  $\Omega \subseteq \mathbb{C}$ . Suppose  $f(z)$  is continuous on  $\gamma$ , and has an antiderivative  $F \in \Omega$ . Then

$$\int_{\gamma} f(z) dz = F(\gamma(b)) - F(\gamma(a)) \quad (12.1)$$

---

##### Proof

Let  $G = F \circ \gamma$  and suppose  $\gamma$  is a smooth function. Since  $\gamma$  is smooth,  $\gamma'$  exists and is continuous on  $[a, b]$  and  $\gamma'(t) \neq 0$  for all  $t \in [a, b]$ , and since  $f$  is continuous on  $[a, b]$ ,  $G(t) = F(\gamma(t))\gamma'(t)$  is continuous as well.

Now

$$\begin{aligned}
 \int_{\gamma} f(z) dz &= \int_a^b f(\gamma(t)) \gamma'(t) dt \\
 &= \int_a^b F'(\gamma(t)) \gamma'(t) dt \\
 &= \int_a^b G'(t) dt \\
 &= G(b) - G(a) \quad \text{by applying FTC in } \mathbb{R} \text{ to real and imaginary parts} \\
 &= F(\gamma(b)) - F(\gamma(a))
 \end{aligned}$$

If  $\gamma$  is piecewise smooth, then we can simply apply the above to each of the smooth paths separately and sum up all of the integrals.  $\square$

### Definition 18 (Closed Path)

A path  $\gamma : [a, b] \rightarrow \mathbb{C}$  is said to be **closed** if  $\gamma(a) = \gamma(b)$ .

### Corollary 11 (Corollary of FTC)

If  $F \in H(\Omega)$ ,  $\Omega \subseteq \mathbb{C}$  (hence  $F'$  is continuous on  $\Omega$ ), then

$$\int_{\gamma} F'(z) dz = 0$$

on any closed path  $\gamma$  on  $\Omega$ .

### Proof

A closed path  $\gamma : [a, b] \rightarrow \mathbb{C}$  has  $\gamma(a) = \gamma(b)$ . By  Theorem 10,

$$\int_{\gamma} F'(z) dz = F(\gamma(b)) - F(\gamma(a)) = 0 \text{ as required.} \quad \square$$

### Example 12.1.1

Take  $f(z) = z^n$  where  $n \in \mathbb{Z} \setminus \{-1\}$  as in Example 11.1.2. Then  $f$  is continuous on  $\mathbb{C} \setminus \{0\}$  (**not sure why this would be problematic when we've already excluded -1 for n**). Then  $f = F'$  for  $F(z) = \frac{z^{n+1}}{n+1}$  and  $F \in H(\mathbb{C} \setminus \{0\})$ . Therefore by  Corollary 11,  $\int_{\gamma} z^n dz = 0$  for any closed path  $\gamma$  not passing through 0.



If we do include  $-1$  for  $n$ , note that  $F'$  would not be continuous on  $0$ , and thus the corollary would not apply. We have also shown in the earlier example that  $\int_{\gamma} \frac{1}{z} dz = 2\pi i$ .

---

### “ Note (Recall)

The **interior** of a set  $\Omega$  is defined as  $\{z \in \Omega : \forall \varepsilon > 0 B(z, \varepsilon) \subseteq \Omega\}$ , and denoted as  $\Omega^0$ .

---

### ▣ Theorem 12 (Goursat's Theorem / Cauchy's Theorem for a triangle)

Let  $\Omega \subseteq \mathbb{C}$  be an open set. Suppose  $\Delta \subseteq \Omega$  is a closed triangle whose interior is also contained in  $\Omega$ . Let  $f \in H(\Omega)$ . Then

$$\int_{\Delta} f(z) dz = 0$$

---

This theorem holds more meaning than the presented statement, as it implies that, essentially, given any two points connected by two different paths in an open set in  $\mathbb{C}$ , and a function that is holomorphic over the two paths, the **two path integrals of the function will yield the same result!**

---

### ✎ Proof

Let  $\Delta_1^{(1)}, \Delta_2^{(1)}, \Delta_3^{(1)}, \Delta_4^{(1)}$  be smaller triangles by bisecting each side of  $\Delta$ .  $\forall i \in \{1, 2, 3, 4\}$ , orient  $\Delta_i^{(1)}$  anticlockwise. Then we have

$$J := \int_{\Delta} f(z) dz = \sum_{i=1}^4 \int_{\Delta_i^{(1)}} f(z) dz \quad (12.2)$$

Note that there must at least one of the  $\Delta_i^{(1)}$  such that  $\left| \int_{\Delta_i^{(1)}} f(z) dz \right| \geq \frac{|J|}{4}$ , since  $\forall i \in \{1, 2, 3, 4\}$ ,  $\left| \int_{\Delta_i^{(1)}} f(z) dz \right| < \frac{|J|}{4}$  would contradict Equation (12.2). Without loss of generality, let  $\Delta_1^{(1)}$  be the largest triangle of the four.

Now note that each of the perimeter of  $\Delta_i^{(1)}$  is half of the perimeter of  $\Delta$ . Let  $\ell(x)$  be the perimeter of  $x$ . Continue with taking bisectors of



# Tutorial Jan 31 2018

---

## “ Note

Consider the power series  $\sum_{n \geq 0} a_n (z - z_0)^n$  and let  $\frac{1}{R} := \limsup_{n \rightarrow \infty} \sup \sqrt[n]{|a_n|} \in [0, \infty)$ .

- If  $|z - z_0| < R$ ,  $\sum_{n \geq 0} a_n (z - z_0)^n$  converges absolutely.
  - If  $|z - z_0| > R$ ,  $\sum_{n \geq 0} a_n (z - z_0)^n$  diverges.
  - If  $0 < r < R$ , then  $\sum_{n \geq 0} a_n (z - z_0)^n$  converges uniformly on  $\{z : |z - z_0| < r\}$ .
- 

## 12.2 Practice Problems

1. Parameterize the semicircle  $|z - 4 - 5i| = 3$  clockwise, starting from  $z = 4 + 8i$  to  $z = 4 + 2i$ .

### Solution

Let  $\gamma : [-\frac{\pi}{2}, \frac{\pi}{2}] \rightarrow \mathbb{C}$  such that  $\gamma(t) = 3e^{-it} + 4 + 5i$ . Note that  $\gamma$  parameterizes the given semicircle:

$$\gamma\left(-\frac{\pi}{2}\right) = 4 + 8i$$

$$\gamma(0) = 7 + 5i$$

$$\gamma\left(\frac{\pi}{2}\right) = 4 + 2i$$

2. If the power series  $f(z) = \sum_{n=0}^{\infty} c_n (z - z_0)^n$  centered at  $z_0$  has a

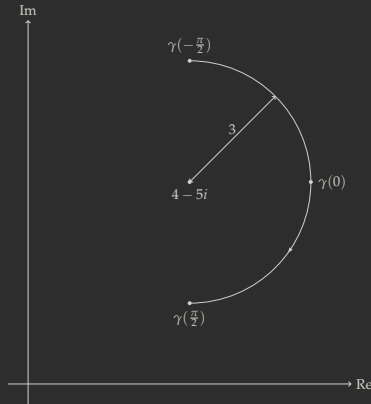
Figure 12.1: Semicircle  $|z - 4 - 5i| = 3$  oriented clockwise, parameterized by  $\gamma$ 

non-zero radius of convergence, then show that

$$c_m = \frac{f^{(m)}(z_0)}{m!}$$

for any  $m \in \mathbb{Z}, m \geq 0$ , where  $f^{(m)}(z_0)$  denotes the  $m$ th derivative of  $f$  at  $z_0$ .

**Solution**

Since  $f(z)$  is a power series and the radius of convergence  $R \neq 0$ , by **Theorem 7**,  $f(z)$  is  $\mathbb{C}$ -differentiable and each derivative has the same radius of convergence. By induction, it can be shown that

$$f^{(m)}(z) = \sum_{n=m}^{\infty} \frac{n!}{(n-m)!} c_n (z - z_0)^{n-m}$$

Evaluating  $f^{(m)}$  at  $z_0$ , we have

$$\begin{aligned} f^{(m)}(z_0) &= \sum_{n=m}^{\infty} \frac{n!}{(n-m)!} c_n (z_0 - z_0)^{n-m} \\ &= m! c_m \end{aligned}$$

where all terms above  $m$  are 0. Then we obtain

$$c_m = \frac{f^{(m)}(z_0)}{m!}$$

as desired. □

3. Let  $\gamma$  be the arc of the unit circle centered at the origin in the first quadrant oriented clockwise (from  $i$  to  $1$ ). Evaluate the integral

$$\int_{\gamma} \bar{z}^2 dz$$

by parameterizing the curve.

 **Solution**

Consider the parameterization  $\gamma : [-\frac{\pi}{2}, 0] \rightarrow \mathbb{C}$  given by  $\gamma(t) = e^{-it}$ .

Note that  $e^{-it} = e^{it}$ . Then

$$\begin{aligned} \int_{\gamma} \bar{z}^2 dz &= \int_{-\frac{\pi}{2}}^0 e^{2it} \cdot (-ie^{-it}) dt \\ &= -i \int_{-\frac{\pi}{2}}^0 e^{it} dt \\ &= -e^{it} \Big|_{-\frac{\pi}{2}}^0 \\ &= -1 - i \end{aligned}$$

□

4. Evaluate the above integral by finding an antiderivative. (Hint: Use  $(\frac{z\bar{z}}{z})^2$ )

 **Solution**

Note that  $z\bar{z} = |z|^2$ , so on the circle, we have  $\bar{z} = \frac{1}{z}$ . Thus the integral is equivalent to

$$\int_{\gamma} \frac{1}{z^2} dz$$

Note that the antiderivative of  $\frac{1}{z^2}$  is  $-\frac{1}{z}$ . Thus by  Theorem 10,

$$\int_{\gamma} \bar{z}^2 dz = \int_{\gamma} \frac{1}{z^2} dz = F(\gamma(0)) - F\left(\gamma\left(-\frac{\pi}{2}\right)\right) = -\frac{1}{e^{-i(0)}} + \frac{1}{e^{-i(-\pi/2)}} = -1 - i$$

5. Let  $\{c_n\}_{n=0}^{\infty}$  be a sequence of positive real numbers such that

$$L = \lim_{n \rightarrow \infty} \frac{c_{n+1}}{c_n}$$

exists. Then show that

$$\lim_{n \rightarrow \infty} c_n^{\frac{1}{n}} = L$$

This shows that, when applicable, the **ratio test** can be used instead of the root test to calculate the radius of convergence of a power series.

 **Solution**

Suppose that

$$L = \lim_{n \rightarrow \infty} \frac{c_{n+1}}{c_n}$$

exists. By definition, we have

$$\forall \varepsilon > 0 \exists N \in \mathbb{N} \forall n > N$$

$$\left| \frac{c_n}{c_{n-1}} - L \right| < \varepsilon$$

Thus for  $n \geq N$ ,

$$c_n^{\frac{1}{n}} = \left( \frac{c_n}{c_{n-1}} \cdot \frac{c_{n-1}}{c_{n-2}} \cdots \frac{c_N}{c_{N-1}} \cdot c_{N-1} \right)^{\frac{1}{n}}$$

$$= \left( \frac{c_n}{c_{n-1}} \right)^{\frac{1}{n}} \left( \frac{c_{n-1}}{c_{n-2}} \right)^{\frac{1}{n}} \cdots \left( \frac{c_N}{c_{N-1}} \right)^{\frac{1}{n}} c_{N-1}^{\frac{1}{n}}$$

Now

$$(L - \varepsilon)^{\frac{1}{n}} (L - \varepsilon)^{\frac{1}{n}} \cdots (L - \varepsilon)^{\frac{1}{n}} c_{N-1}^{\frac{1}{n}} \leq c_n^{\frac{1}{n}} \leq (L + \varepsilon)^{\frac{1}{n}} (L + \varepsilon)^{\frac{1}{n}} \cdots (L + \varepsilon)^{\frac{1}{n}} c_{N-1}^{\frac{1}{n}}$$

$$(L - \varepsilon)^{\frac{n-N+1}{n}} c_{N-1}^{\frac{1}{n}} \leq c_n^{\frac{1}{n}} \leq (L + \varepsilon)^{\frac{n-N+1}{n}} c_{N-1}^{\frac{1}{n}}$$

Note that

$$\lim_{n \rightarrow \infty} (L - \varepsilon)^{\frac{n-N+1}{n}} c_{N-1}^{\frac{1}{n}} = L - \varepsilon$$

$$\lim_{n \rightarrow \infty} (L + \varepsilon)^{\frac{n-N+1}{n}} c_{N-1}^{\frac{1}{n}} = L + \varepsilon$$

Thus we have

$$L - \varepsilon \leq c_n^{\frac{1}{n}} \leq L + \varepsilon$$

$$\left| c_n^{\frac{1}{n}} - L \right| \leq \varepsilon$$

as desired. □

6. Find the radius of convergence of

(a)  $\sum_{n=0}^{\infty} \frac{n^n z^n}{n!}$

(b)  $\sum_{n=0}^{\infty} z^{2^n}$

 **Solution**

(a) By Stirling's Approximation, i.e.  $n! \sim \left(\frac{n}{e}\right)^n \sqrt{2\pi n}$ , we have that

Hadamard's formula is

$$\begin{aligned}
 \frac{1}{R} &= \limsup_{n \rightarrow \infty} \left| \frac{n^n}{n!} \right|^{\frac{1}{n}} \\
 &= \limsup_{n \rightarrow \infty} \left| \frac{n^n}{\left(\frac{n}{e}\right)^n \sqrt{2\pi n}} \right|^{\frac{1}{n}} \\
 &= \limsup_{n \rightarrow \infty} \left| \frac{e^n}{\sqrt{2\pi n}} \right|^{\frac{1}{n}} \\
 &= e \limsup_{n \rightarrow \infty} \left| \frac{1}{\sqrt{2\pi n}} \right|^{\frac{1}{n}} = e
 \end{aligned}$$

Therefore,  $R = \frac{1}{e}$ .

(b) *no solution yet: current problem, not being able to express the sum as a power series, in turn failing to get  $c_n$  which is needed for  $\frac{1}{R}$ .*

7. Show that for any path  $\gamma : [a, b] \rightarrow \mathbb{C}$  and  $f(z)$  continuous on  $\gamma$ , we have

$$\left| \int_{\gamma} f(z) dz \right| \leq \sup_{z \in \gamma} |f(z)| \int_a^b |\gamma'(t)| dt$$

 **Solution**

$$\begin{aligned}
 LHS &= \left| \int_{\gamma} f(z) dz \right| \\
 &= \left| \int_a^b f(\gamma(t)) \gamma'(t) dt \right| \text{ by definition} \\
 &\leq \int_a^b |f(\gamma(t)) \gamma'(t)| dt \text{ by Item 2a of Proposition 9} \\
 &\leq \int_a^b \sup_{z \in \gamma} |f(z)| |\gamma'(t)| dt \text{ since } |f(z)| \leq \sup_{z \in \gamma} |f(z)| \\
 &= \sup_{z \in \gamma} |f(z)| \cdot \int_a^b |\gamma'(t)| dt = RHS
 \end{aligned}$$





# 13 Lecture 13 Feb 9th 2018

## 13.1 Cauchy's Integral Formula

### Definition 19 (Convex Set)

A set  $S \subseteq \mathbb{C}$  is called a **convex set** if the line segment joining any pair of points in  $S$  lies entirely in  $S$ .

### Theorem 13 (Cauchy's Theorem for Convex Set)

Let  $\Omega \subseteq \mathbb{C}$  be a convex open set, and  $f \in H(\Omega)$ . Then

1.  $f = F'$  for some  $F \in H(\Omega)$ .
2.  $\int_{\gamma} f(z) dz = 0$  for any closed path  $\gamma \in \Omega$ .

### Proof

Note that it is sufficient to prove 1 since  $1 \implies 2$  by  Theorem 10.

Let  $a \in \Omega$ , and let  $[a, z]$  denote the straight line from  $a$  to  $z$ . Since  $\Omega$  is a convex set,  $[a, z]$  is in  $\Omega$ . Define  $F(z)^1 = \int_{[a, z]} f(z) dz^2$ .

**WTS**  $F \in H(\Omega)$ ,  $F'(z_0) = f(z_0)$  for any  $z_0 \in \Omega$ .

Now by  Theorem 12,

<sup>1</sup> It can be verified that  $F$  is continuous.  
<sup>2</sup> This is a key step: defining an "antiderivative" as how we would expect it to be.

$$\begin{aligned}
 0 &= \int_{\Delta} f(z) dz \\
 &= \int_{[a,z]} f(z) dz + \int_{[z,z_0]} f(z) dz + \int_{[z_0,a]} f(z) dz \\
 &= F(z) + \int_{[z,z_0]} f(z) dz + (-F(z_0))
 \end{aligned}$$

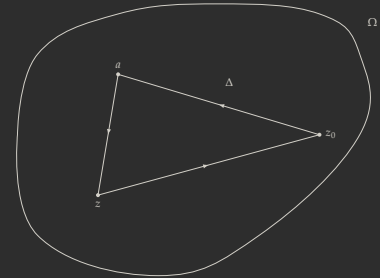

This implies that

$$F(z) - F(z_0) = \int_{[z_0,z]} f(z) dz.$$

Divide both sides by  $z - z_0$ , then

$$\begin{aligned}
 \frac{F(z) - F(z_0)}{z - z_0} - f(z_0) &= \frac{1}{z - z_0} \int_{[z_0,z]} f(z) dz - f(z_0) \\
 &= \frac{1}{z - z_0} \int_{[z_0,z]} f(z) - f(z_0) dz \quad \text{since } \int_{[z_0,z]} dz = z - z_0
 \end{aligned}$$

Since  $f \in H(\Omega)$  and is hence continuous, we have that

$$\begin{aligned}
 \forall \epsilon > 0 \exists \delta > 0 \\
 |z - z_0| < \delta \implies |f(z) - f(z_0)| < \epsilon
 \end{aligned}$$

which in turn implies that

$$\left| \frac{F(z) - F(z_0)}{z - z_0} - f(z_0) \right| = \left| \frac{1}{z - z_0} \int_{[z_0,z]} [f(z) - f(z_0)] dz \right| \leq \frac{1}{|z - z_0|} \left| \int_{[z_0,z]} \epsilon dz \right| = \epsilon$$

Hence, by first principle,  $F'(z_0) = f(z_0)$ . □

### ■ Theorem 14 (Cauchy's Integral Formula 1)

Let  $\Omega \subseteq \mathbb{C}$  be a convex open set, and  $C$  be a closed circle path in  $\Omega$ . If  $w \in \Omega \setminus \partial C$ , where  $\partial C$  is the **boundary of  $C$** , and  $f \in H(\Omega)$ , then

$$f(w) \text{Ind}_C(w) = \frac{1}{2\pi i} \int_C \frac{f(z)}{z - w} dz$$

where

$$\text{Ind}_C(w) = \frac{1}{2\pi i} \int_{\gamma} \frac{dz}{z - w}$$

denotes the number of times the countour  $C$  winds around the point  $w$ .

is called the **index of  $w$  with respect to  $C$** , or the **winding number**

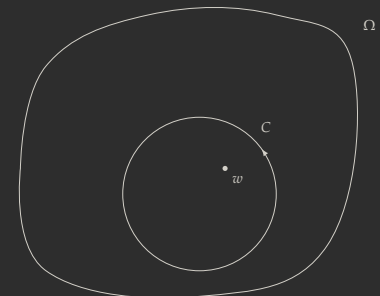

of  $C$  around  $w$ .

**Proof**

Let  $w \in \Omega \setminus \partial C$ . Define

$$g(w) = \begin{cases} \frac{f(z)-f(w)}{z-w} & \text{if } z \neq w \\ f'(w) & \text{if } z = w \end{cases}$$

By the construction of  $g$ ,  $g$  is continuous on  $\Omega$ , and  $g \in H(\Omega \setminus \{w\})$ .

**We need to** construct a convex set  $\Omega' \subseteq \Omega$  that contains  $\gamma_{\delta,\varepsilon}$  such that  $g \in H(\Omega')$ .

We now follow a similar argument as in the proof for **Theorem 13**. Let  $\varepsilon > 0$  such that  $\exists \delta > 0$ , so that we can define the “keyhole”  $\gamma_{\delta,\varepsilon}$  which omits  $w$ . Consider  $D(w, \varepsilon)$ , call the image of the border of  $D(w, \varepsilon)$  as  $C_\varepsilon$ , let  $\delta$  be the width of the “corridor”, and the two paths that are the “sides of the corridor” be called  $C_{\delta_1}, C_{\delta_2}$  respectively. Define  $G(z) = \int_{[a,z]} g(z) dz$ , where  $a$  and  $z$  are in the interior of  $C$  but not in the interior of  $C_\varepsilon$ . Then if we define a set  $\Omega'$  such that it contains the interior of  $\gamma_{\delta,\varepsilon}$ , we have that  $\Omega'$  is a convex open set, and  $G \in H(\Omega')$ . By **Theorem 13**,  $G' = g$ .

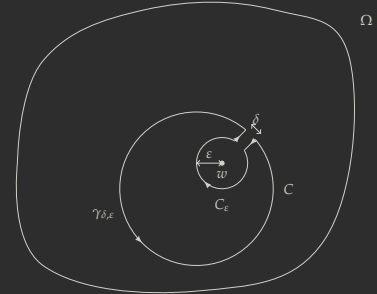

Also from **Theorem 13**, we have that  $\int_{\gamma_{\delta,\varepsilon}} g(z) dz = 0$  for any  $\varepsilon, \delta > 0$ . As  $\delta \rightarrow 0^+$ , we have that the integrals over  $C_{\delta_1}$  and  $C_{\delta_2}$  cancel out. Hence, we are left with

$$\int_C g(z) dz + \int_{C_\varepsilon} g(z) dz = 0$$

Let's put our focus on the smaller circle,  $C_\varepsilon$ . Now as  $\varepsilon \rightarrow 0^+$ ,  $\frac{f(z)-f(w)}{z-w} \rightarrow 0$ , and thus

$$\int_{C_\varepsilon} g(z) dz = \int_{C_\varepsilon} \frac{f(z) - f(w)}{z - w} dz \rightarrow 0$$

Therefore,

$$\int_C g(z) dz = 0$$

which implies, in the limit, that

$$\int_C \frac{f(z)}{z-w} dz = \int_C \frac{f(w)}{z-w} dz = f(w) \int_C \frac{dz}{z-w}$$



## 14 Lecture 14 Feb 12 2018

### 14.1 Cauchy's Integral Formula (Continued)

#### 🌲 Lemma 15

(Lemma and proof from Newman & Bak on Complex Analysis, 3rd Ed.)

Suppose  $a \in \mathbb{C}_\rho^0$  such that  $\exists \alpha \in \mathbb{C}_\rho$  that is the center of the circle  $C_\rho$ , where  $\rho$  is the radius of  $C_\rho$ , and hence  $|a - \alpha| < \rho$ . Then

$$\int_{C_\rho} \frac{dz}{z - a} = 2\pi i$$

#### ✏️ Proof

Let  $z \equiv \alpha + \rho e^{i\theta}$ , then  $dz = i\rho e^{i\theta} d\theta$ . Thus

$$\int_{C_\rho} \frac{dz}{z - \alpha} = \int_0^{2\pi} \frac{i\rho e^{i\theta}}{\rho e^{i\theta}} d\theta = 2\pi i$$

while

$$\int_{C_\rho} \frac{dz}{(z - \alpha)^{k+1}} = 0 \quad \text{for } k = 1, 2, 3, \dots \quad (14.1)$$

The Equation (14.1) follows not only from a direct evaluation of the integral

$$\int_{C_\rho} \frac{dz}{(z - \alpha)^{k+1}} = \int_0^{2\pi} \frac{i\rho e^{i\theta}}{(\rho e^{i\theta})^{k+1}} d\theta = \frac{i}{\rho^k} \int_0^{2\pi} e^{-ik\theta} d\theta = 0$$

but also the fact that  $\frac{1}{(z - \alpha)^{k+1}}$  is the derivative of  $-\frac{1}{k(z - \alpha)^k}$ , which can be verified to be holomorphic on  $C_\rho$ , which simply makes Equation (14.1)

true by  Theorem 10.

To evaluate  $\int_{C_\rho} \frac{dz}{z-a}$ , write

$$\begin{aligned} \frac{1}{z-a} &= \frac{1}{(z-\alpha) - (a-\alpha)} = \frac{1}{(z-\alpha)\left[1 - \frac{a-\alpha}{z-\alpha}\right]} \\ &= \frac{1}{z-\alpha} \cdot \frac{1}{1-\omega} \end{aligned}$$

where

$$\omega = \frac{a-\alpha}{z-\alpha} \text{ has fixed modulus } \frac{|a-\alpha|}{\rho} < 1 \text{ throughout } C_\rho \quad (14.2)$$

By Equation (14.2) and by the **Infinite Geometric Sum** that  $\frac{1}{1-\omega} = 1 + \omega + \omega^2 + \dots$ , we get

$$\begin{aligned} \frac{1}{z-a} &= \frac{1}{z-\alpha} \left[ 1 + \frac{a-\alpha}{z-\alpha} + \frac{(a-\alpha)^2}{(z-\alpha)^2} + \dots \right] \\ &= \frac{1}{z-\alpha} + \frac{a-\alpha}{(z-\alpha)^2} + \frac{(a-\alpha)^2}{(z-\alpha)^3} + \dots \end{aligned}$$

Since the convergence is uniform throughout  $C_\rho$ ,

$$\int_{C_\rho} \frac{1}{z-a} dz = \int_{C_\rho} \frac{1}{z-\alpha} dz + \sum_{k=1}^{\infty} \int_{C_\rho} \frac{(a-\alpha)^k}{(z-\alpha)^{k+1}} dz = 2\pi i$$

□

We may now continue with completing the previous proof.

 **Proof (Continued -  Theorem 14)**

Lemma 15 completes the part where we required  $\int_C \frac{dz}{z-w} = 2\pi i$ .

We now have

$$f(w) = \frac{1}{2\pi i} \int_C \frac{f(z)}{z-w} dz$$

Now note that if we further generalize the number of times the contour  $C_\rho$  made around  $a$ , where in this case  $C_\rho$  is a closed path instead of a simple circle in  $\Omega$ , in Lemma 15, we would get  $\int_{C_\rho} \frac{dz}{z-a} = 2k\pi i$  where  $k$  would represent that number.

In this case, we would get

$$f(w)k = \frac{1}{2\pi i} \int_C \frac{f(z)}{z-w} dz$$

where  $k = \text{Ind}_C(w) = \frac{1}{2\pi i} \int_C \frac{dz}{z-w}$  which represents the number of times the contour  $C$  winds around  $w$ . □

**Remark**

As noted,  **Theorem 14** holds for any closed path  $\gamma \in \Omega$  instead of a simple circle  $C$ . If  $w \in \Omega \setminus \gamma^*$ , we get

$$\frac{1}{2\pi i} \int_{\gamma} \frac{f(z)}{z-w} dz = f(w) \text{Ind}_{\gamma}(w)$$

 **Proposition 16 (Holomorphic Functions can be expressed as Power series)**

Let  $\Omega \subseteq \mathbb{C}$  be an open set,  $f \in H(\Omega)$ . Then  $f$  can be expressed as a power series.

 **Proof**

$\forall w \in \Omega, \exists C \subseteq \Omega$  that is a closed circle path with  $w \in C^0$ . By  **Theorem 14**, and since  $C$  is a circle, i.e. the contour winds around  $w$  only once, we have

$$f(w) = \frac{1}{2\pi i} \int_C \frac{f(z)}{z-w} dz.$$

Let  $w_0 \in \Omega$  be the center of  $C$ . Then  $\forall z \in \partial C, 0 < |w - w_0| < |z - w_0|^1$ . This implies that

<sup>1</sup> This is the key step

$$0 < \frac{|w - w_0|}{|z - w_0|} < 1$$

$$\implies \sum_{n=0}^{\infty} \left( \frac{w - w_0}{z - w_0} \right)^n = \frac{1}{1 - \frac{w - w_0}{z - w_0}} = \frac{z - w_0}{z - w} \text{ by the Infinite Geometric Sum}$$

$$\implies \frac{1}{2\pi i} \int_C \frac{f(z)}{z-w} dz = \frac{1}{2\pi i} \int_C \frac{f(z)}{z-w_0} \frac{z-w_0}{z-w} dz = \frac{1}{2\pi i} \int_C \frac{f(z)}{z-w_0} \sum_{n=0}^{\infty} \left( \frac{w - w_0}{z - w_0} \right)^n dz$$

Note that each of the terms in the integrand of the last expression are absolutely convergent, thus by **Fubini's Theorem**, we can interchange the summation and integral sign to get

$$f(w) = \sum_{n=0}^{\infty} \underbrace{\left[ \frac{1}{2\pi i} \int_C \frac{f(z)}{(z-w_0)^{n+1}} dz \right]}_{a_n} (w - w_0)^n$$

which is a power series centered at  $w_0$  with coefficient  $a_n$ .

### 66 Note (Recall)

Consider the power series  $f(w) = \sum_{n=0}^{\infty} a_n(w - w_0)^n$ . Recall Item 2 from Section 12.2 that

$$a_n = \frac{f^{(n)}(w_0)}{n!}$$

Applying this to  $\heartsuit$  Proposition 16, we get

$$\frac{f^{(n)}(w_0)}{n!} = \frac{1}{2\pi i} \int_C \frac{f(z)}{(z - w_0)^{n+1}} dz$$

which holds for any  $w_0 \in \Omega$  by having  $C \subseteq \Omega$  centered at  $w_0$ .

### $\blacksquare$ Theorem 17 (Cauchy's Integral Formula 2)

Let  $\Omega \subseteq \mathbb{C}$  be open,  $f \in H(\Omega)$ . Then

1.  $\forall w \in \Omega$ ,  $f$  has a power series expansion at  $w$ .
2.  $f$  is differentiable infinitely many times in  $\Omega$ .
3.  $\forall C \subseteq \Omega$  that is a closed circle oriented anticlockwise, we have that  $\forall w \in C^0$ ,

$$f^{(n)}(w) = \frac{n!}{2\pi i} \int_C \frac{f(z)}{(z - w)^{n+1}} dz \quad (14.3)$$

### Remark

Item 3 is the actual Cauchy's Integral Formula in the theorem.

### $\pencil$ Proof

We have shown 1 from  $\heartsuit$  Proposition 16 and 2 from  $\blacksquare$  Theorem 7. It remains to prove 3, which we shall prove by induction.

When  $n = 0$ , it is simply  $\blacksquare$  Theorem 14. Suppose  $f$  has up to  $n - 1$  complex derivatives and that

$$f^{(n-1)}(w) = \frac{(n-1)!}{2\pi i} \int_C \frac{f(z)}{(z - w)^n} dz.$$



Consider  $h > 0$ , the difference of the quotient for  $f^{(n-1)}$  is

$$\frac{f^{(n-1)}(w-h) - f^{(n-1)}(w)}{h} = \frac{(n-1)!}{2\pi i} \int_C f(z) \frac{1}{h} \left[ \frac{1}{z-w-h} - \frac{1}{z-w} \right] dz \tag{14.4}$$

Note that

$$A^n - B^n = (A - B)(A^{n-1} + A^{n-2}B + \dots + AB^{n-2} + B^{n-1})$$

Let  $A = \frac{1}{z-w-h}$ ,  $B = \frac{1}{z-w}$ , then the term in square brackets in Equation (14.4) becomes <sup>2</sup>Key step

$$\frac{h}{(z-w-h)(z-w)} \left[ A^{n-1} + A^{n-2}B + \dots + AB^{n-2} + B^{n-1} \right]$$

Thus as  $h \rightarrow 0$ , we have

$$f^{(n)} = \frac{(n-1)!}{2\pi i} \int_C f(z) \left[ \frac{1}{(z-w)^2} \right] \left[ \frac{n}{(z-w)^{n-1}} \right] dz = \frac{n!}{2\pi i} \int_C \frac{f(z)}{(z-w)^{n+1}} dz$$

which completes the induction proof and proves 3. □

➤ **Corollary 18 (Taylor Expansion of Entire Functions)**

If  $f$  is an entire function, then  $\forall z_0 \in \mathbb{C}$ , we have

$$f(z) = f(z_0) + f'(z_0)(z - z_0) + \frac{f''(z_0)}{2!}(z - z_0)^2 + \dots$$

which is a **Taylor Expansion** of  $f$  around  $z_0$ .

**Proof**

By Proposition 16, we have that

$$\begin{aligned} f(z) &= \sum_{n=0}^{\infty} \left[ \frac{1}{2\pi i} \int_C \frac{f(w)}{(w - z_0)^{n+1}} dw \right] (z - z_0)^n \\ &= \frac{1}{2\pi i} \int_C \frac{f(w)}{w - z_0} dw + \left[ \frac{1}{2\pi i} \int_C \frac{f(w)}{(w - z_0)^2} \right] (z - z_0) \tag{14.5} \\ &\quad + \left[ \frac{1}{2\pi i} \int_C \frac{f(w)}{(w - z_0)^3} dw \right] (z - z_0)^2 + \dots \\ &\quad + \left[ \frac{1}{2\pi i} \int_C \frac{f(w)}{(w - z_0)^{k+1}} dw \right] (z - z_0)^k + \dots \end{aligned}$$



## 15 Lecture 15 Feb 14th 2018

### 15.1 Cauchy's Integral Formula (Continued 1)

At this point, it is important that we provide the following definition:

---

#### Definition 20 (Analytic Functions)

We say that  $f$  is **analytic** in  $\Omega$  if  $f$  has a power series expansion at every  $z \in \Omega$ .

---

#### Remark

1. We have proven, in the previous lecture, that Holomorphicity  $\implies$  Analyticity
2. Should we have defined, in  Theorem 17, that the closed circle orients clockwise, then we would have a negative equation for Equation (14.3).

### 15.1.1 Applications of Cauchy's Integral Formula

#### Exercise 15.1.1

1. **(Cauchy's Inequality)**<sup>1</sup> Prove that  $\forall z_0 \in \mathbb{C} \forall R > 0 \in \mathbb{R} \forall f \in H(\mathbb{C} = D(z_0, R))$

$$f^{(n)}(z_0) \leq \frac{n!}{R^n} \cdot \sup_{z \in \mathbb{C}} |f(z)|$$

<sup>1</sup> In a sense, this inequality implies that as we take higher derivatives, the value of the derivatives become smaller.

---

**✎ Proof**

From Equation (14.3), we have

$$f^{(n)}(z_0) = \frac{n!}{2\pi i} \int_C \frac{f(z)}{(z - z_0)^{n+1}} dz$$

Parameterize  $C$  with  $\gamma : [0, 2\pi] \rightarrow \mathbb{C}$ , where  $t \mapsto z_0 + Re^{it}$ . Then

$$\begin{aligned} f^{(n)}(z_0) &= \frac{n!}{2\pi i} \int_0^{2\pi} \frac{f(z_0 + Re^{it})}{(Re^{it})^{n+1}} Rie^{it} dt \\ |f^{(n)}(z_0)| &\leq \frac{n!}{2\pi} \int_0^{2\pi} \frac{|f(z_0 + Re^{it})|}{R^n} dt \quad \because |Re^{it}| = R \\ &\leq \frac{n!}{2\pi R^n} \sup_{z \in C} |f(z)| \int_0^{2\pi} dt \\ &= \frac{n!}{R^n} \sup_{z \in C} |f(z)| \end{aligned}$$

This completes the proof.  $\square$

2. **(Liouville's Theorem)** A bounded entire function  $f : \mathbb{C} \rightarrow \mathbb{C}$  is a constant<sup>2</sup> <sup>3</sup>.

<sup>2</sup> The theorem is not true in  $\mathbb{R}$ , since  $\sin x$  is a bounded function differentiable everywhere, but is not a constant.

<sup>3</sup> The theorem also implies that "trigonometry" in  $\mathbb{C}$  is unbounded, whatever the definition of "trigonometry" may be.

**✎ Proof**

Since  $f$  is entire, we may take  $R$ , in Item 1, to be any large value.

Let  $M$  be the bound of  $f$ , i.e.  $\exists M \in \mathbb{C}, \forall z_0 \in \mathbb{C}, |f^{(n)}(z_0)| \leq \frac{n!}{R^n} \sup_{z \in C} |f(z)| = \frac{n!}{R^n} \sup_{z \in C} M$ . Let  $n = 1$ , then  $|f'(z_0)| \leq \frac{M}{R}$ . Thus we observe that  $R \rightarrow \infty \implies f'(z_0) \rightarrow 0$  for any  $z_0 \in \mathbb{C}$ . By A2Q5(a),  $f$  is a constant.

3. **(Parseval's Theorem)** Let  $\Omega \subseteq \mathbb{C}$  be open,  $f \in H(\Omega)$ ,  $\overline{D(z_0, R)} \subseteq \Omega$ . Then  $\forall z \in \overline{D(z_0, R)}$ ,  $f(z) = \sum_{n=0}^{\infty} c_n (z - z_0)^n$ , which in turn implies that <sup>4</sup>

$$\forall z \in \overline{D(z_0, R)} \quad f(z_0 + re^{i\theta}) = \sum_{n=0}^{\infty} c_n (re^{i\theta})^n \quad (\dagger)$$

<sup>4</sup> This is why the  $L^2$ -norm is preserved, as seen in AMATH231.

Consider (the  $L^2$ -norm)

$$\begin{aligned}
 & \frac{1}{2\pi} \int_0^{2\pi} |f(z_0 + re^{i\theta})|^2 d\theta \\
 &= \frac{1}{2\pi} \int_0^{2\pi} \left| \sum_{n=0}^{\infty} c_n (re^{i\theta})^n \right|^2 d\theta \\
 &= \frac{1}{2\pi} \int_0^{2\pi} \left[ \sum_{n=0}^{\infty} c_n r^n e^{in\theta} \right] \left[ \sum_{m=0}^{\infty} \overline{c_m} r^m e^{-im\theta} \right] d\theta \\
 &= \frac{1}{2\pi} \int_0^{2\pi} \sum_{n=0}^{\infty} \sum_{m=0}^{\infty} c_n \overline{c_m} r^{n+m} e^{i(n-m)\theta} d\theta
 \end{aligned}$$

Since the series are absolutely convergent, we may use Fubini's Theorem, and thus

$$\begin{aligned}
 &= \frac{1}{2\pi} \sum_{n,m=0}^{\infty} c_n \overline{c_m} r^{n+m} \int_0^{2\pi} e^{i(n-m)\theta} d\theta \\
 &= \begin{cases} \frac{1}{2\pi} \sum_{n,m=0}^{\infty} c_n \overline{c_m} r^{n+m} 2\pi & \text{if } n = m \\ \frac{1}{2\pi} \sum_{n,m=0}^{\infty} c_n \overline{c_m} r^{n+m} \frac{e^{i(n-m)\theta}}{i(n-m)} \Big|_0^{2\pi} = 0 & \text{if } n \neq m \end{cases} \\
 &= \sum_{n=0}^{\infty} |c_n|^2 r^{2n} \quad \text{if } n = m
 \end{aligned}$$

Therefore, we have what is known as **Parseval's Identity**:

$$\frac{1}{2\pi} \int_0^{2\pi} |f(z_0 + re^{i\theta})|^2 d\theta = \sum_{n=0}^{\infty} |c_n|^2 r^{2n} \quad (15.1)$$

Parseval's Theorem states that:

$L^2$ -norm of LHS in Equation (15.1) =  $L^2$ -norm of RHS of Equation (†)

Before going into the next application, please see Lemma 19.

4. (**Maximum Modulus Principle**) Let  $\Omega \subseteq \mathbb{C}$  be open and connected, and  $f \in H(\Omega)$ . Then

$$\sup_{z \in \Omega} |f(z)| = \max_{z \in \partial\Omega} |f(z)|.$$

This implies that  $f$  cannot attain its maximum value in  $\Omega^0$ .

#### Proof

Suppose not, i.e.  $\exists z_0 \in \Omega^0, \forall z \in \Omega$  such that  $|f(z_0)| = \max_{z \in \Omega} |f(z)| \geq$

$$|f(z)|$$

$$\implies \exists r > 0 \quad \overline{D(z_0, r)} \subseteq \Omega$$

$$\implies \forall z \in \overline{D(z_0, r)} \quad f(z) = \sum_{n=0}^{\infty} c_n (z - z_0)^n$$

Note that  $c_0 = \frac{f^{(0)}(z_0)}{0!} = f(z_0)$ . By Item 3,

$$\begin{aligned} \sum_{n=0}^{\infty} |c_n|^2 r^{2n} &= \frac{1}{2\pi} \int_0^{2\pi} |f(z_0 + re^{i\theta})|^2 d\theta \\ \implies f(z_0)^2 + \sum_{n=1}^{\infty} |c_n|^2 r^{2n} &= \frac{1}{2\pi} \int_0^{2\pi} |f(z_0 + re^{i\theta})|^2 d\theta \\ &\leq \frac{1}{2\pi} |f(z_0)|^2 (2\pi) \quad \because f(z_0) = \max_{z \in \Omega} f(z) \\ \implies f(z_0)^2 + \sum_{n=1}^{\infty} |c_n|^2 r^{2n} &\leq |f(z_0)|^2 \\ \implies \sum_{n=1}^{\infty} |c_n|^2 r^{2n} &\leq 0 \\ \implies c_1, c_2, \dots &= 0 \\ &\implies f \text{ is a constant in } \overline{D(z_0, r)} \\ &\implies f \text{ is a constant in } \Omega \text{ by Lemma 19} \end{aligned}$$

which is a contradiction. □

### 🌲 Lemma 19 (Principle of Analytic Continuation)

Let  $\Omega \subseteq \mathbb{C}$  be open and connected, and  $f \in H(\Omega)$ . Let  $Z(f) = \{a \in \Omega : f(a) = 0\}$ . Then either

- $Z(f) = \Omega$ , i.e.  $\forall z \in \Omega, f(z) = 0$ ; or
- $Z(f)$  has no limit point, i.e. points where  $f = 0$  are isolated

This is a powerful result, since if we can find a small region for where  $f$  is 0 in  $\Omega$ , then  $f$  would be 0 in the entirety of  $\Omega$ . If not, then  $f$  is only 0 at isolated points, i.e. points where  $f = 0$  are all apart from each other.

# 16 Lecture 16 Feb 16th 2018

## 16.1 Cauchy's Integral Formula (Continued 3)

### 16.1.1 Applications of Cauchy's Integral Formula (Continued)

#### Exercise 15.1.1 (Continued)

We shall restate the Item 4 in the following manner.

4. **Maximum Modulus Principle (MMP)** Let  $\Omega \subseteq \mathbb{C}$ ,  $f \in H(\Omega)$ ,  $D_{z_0} = \overline{D(z_0, r)} \subseteq \Omega$ . Then  $|f(z_0)| \leq \max_{z \in \partial D_{z_0}} |f(z)|$  with

$$|f(z_0)| = \max_{z \in \partial D_{z_0}} |f(z)| \iff f \text{ is a constant on } \Omega$$

#### Remark

- (a) This implies that for a non-constant analytic function  $f$ ,  $\forall z \in \Omega^0$ ,  $f(z) \neq \max_{w \in \Omega} f(w)$ .
- (b) Since a global maximum is also a local maximum, we observe that for any smaller region  $\Omega_0 \subseteq \Omega$ ,  $f$  cannot attain its maximum value for any point in  $\Omega_0^0$ . This is a stronger statement than the our previous statement about the MMP.

---

#### Proof

Suppose for that  $f$  has a maximum in  $\Omega^0$ , say at  $z_0$ . Hence  $\exists r > 0$ ,  $D_{z_0} = \overline{D(z_0, r)}$  where

$$|f(z_0)| \geq \max_{z \in D_{z_0}} |f(z)|$$

On  $D_{z_0}$ , we have

$$f(z) = \sum_{n=0}^{\infty} c_n (z - z_0)^n \quad (16.1)$$

Note that  $c_0 = f(z_0)$ . By Item 3, on  $D_{z_0}$ ,

$$\begin{aligned} \sum_{n=0}^{\infty} |c_n|^2 r^{2n} &= \frac{1}{2\pi} \int_0^{2\pi} |f(z_0 + re^{i\theta})|^2 d\theta \quad \text{by Equation (15.1)} \\ &\leq \frac{1}{2\pi} \int_0^{2\pi} |f(z_0)|^2 d\theta \quad \text{by Equation (16.1)} \\ &= |f(z_0)|^2. \end{aligned}$$

Then we have

$$\begin{aligned} |c_0|^2 + \sum_{n=1}^{\infty} |c_n|^2 r^{2n} &= |f(z_0)|^2 \\ |f(z_0)|^2 + \sum_{n=1}^{\infty} |c_n|^2 r^{2n} &= |f(z_0)|^2 \\ \sum_{n=1}^{\infty} |c_n|^2 r^{2n} &= 0 \end{aligned}$$

which  $\implies c_1 = c_2 = \dots = 0$ . Thus  $\forall z \in D_{z_0}$ ,  $f(z) \equiv c_0 \pmod{2\pi}$ . Then by Lemma 19, since  $f(z_0) = c_0$ , as  $f(z) - c_0$  contains  $\overline{D(z - 0, r)}$ , we see that  $f(z) - c_0 \equiv 0$  in  $\Omega$ , which implies the equality of Item 4.  $\square$

5. **Fundamental Theorem of Algebra** (FTA) Any polynomial  $P(z) \in \mathbb{C}[z]$  of degree greater than 1 has precisely  $n$  roots in  $\mathbb{C}$ , given by  $\alpha_1, \alpha_2, \dots, \alpha_n$ .  $P(z)$  can be factored as  $P(z) = A(z - \alpha_1) \dots (z - \alpha_n)$  for some  $A \in \mathbb{C}$ .

 **Proof**

We may write  $P(z) = A(z^n + a_{n-1}z^{n-1} + \dots + a_1z + a_0)$ , which then

$$\frac{P(z)}{z^n} = A \left( 1 + \frac{a_{n-1}}{z} + \dots + \frac{a_1}{z^{n-1}} + \frac{a_0}{z^n} \right)$$

which then, by the Reverse Triangle Inequality,

$$\implies \left| \frac{P(z)}{z^n} \right| \geq |A| \left[ 1 - \frac{|a_{n-1}|}{|z|} - \dots - \frac{|a_1|}{|z^{n-1}|} - \frac{|a_0|}{|z^n|} \right] \quad (16.2)$$

So as  $|z| \rightarrow \infty$ ,  $\left| \frac{P(z)}{z^n} \right| \rightarrow |A|$ , from Equation (16.2). Since  $|z| \rightarrow \infty$ ,  $\exists R > 0$ ,  $\forall |z| > R$ , then  $\forall \theta \in [0, 2\pi]$ ,

$$\left| P(Re^{i\theta}) \right| = |P(z)| \geq \frac{|A|}{2} |z|^n \geq \frac{|A|}{2} R^n$$



Taking  $R$  to be even larger if necessary, we can get

$$\left| P(Re^{i\theta}) \right| \geq |P(0)| \quad (\dagger)$$

Suppose, for contradiction,  $P(z)$  has no root in  $\mathbb{C}$ . Then  $g(z) = \frac{1}{P(z)}$  is an entire function. By Equation  $(\dagger)$ , we have that  $|g(Re^{i\theta})| \leq |g(0)|$  for all  $\theta \in [0, 2\pi]$ . But this contradicts Item 4 unless if  $g(z)$  is constant on  $\mathbb{C}$ , which in turn implies that  $P$  is a constant, but that contradicts that  $P$  has degree greater than 1.

$\therefore P(z)$  has to have a zero in  $\mathbb{C}$ , say  $\alpha_1$ . This implies that

$$P(z) = A(z - \alpha_1)P_1(z)$$

where  $P_1(z) \in \mathbb{C}[z]$ . By repeatedly taking the above steps, inductively so, for  $P_1, P_2, \dots$ , the proof is completed.  $\square$

---



# 17 Lecture 17 Feb 26th 2018

## 17.1 Analytic Continuity

We shall restate the important lemma that we have been using in the last two lectures, and proceed to prove this lemma.

---

### 🌲 Lemma 20 (Principle of Analytic Continuity)

Let  $\Omega \subseteq \mathbb{C}$  be open and connected, and  $f \in H(\Omega)$ . Let  $Z(f) = \{a \in \Omega : f(a) = 0\}$ . Then either

- $Z(f) = \Omega$ , i.e.  $\forall z \in \Omega, f(z) = 0$ ; or
- $Z(f)$  has no limit point, i.e. points where  $f = 0$  are isolated

---

### ✎ Proof

Let  $z_0 \in Z(f)^*$ .

**Step 1:** Show that  $z_0 \in Z(f)^0$ , i.e.  $f$  is identically 0 on some  $\overline{D}(z_0, r) \subseteq \Omega$  for  $r > 0$ .

On  $\overline{D}(z_0, r)$ ,  $f(z) = \sum_{n=0}^{\infty} c_n(z - z_0)^n$ . Suppose  $f$  is not identically 0 on  $\overline{D}(z_0, r)$ . Then  $\exists m \in \mathbb{N}, c_m \neq 0, \forall j < m, c_j = 0$ , i.e.  $f(z) = c_m(z - z_0)^m + c_{m+1}(z - z_0)^{m+1} + \dots$

Define, in  $\Omega$ ,

$$g(z) = \begin{cases} \frac{f(z)}{(z-z_0)^m} & z \in \Omega \setminus \{z_0\} \\ c_m & z = z_0 \end{cases}$$

Clearly,  $g \in H(\Omega \setminus \{z_0\})$ . But on  $\overline{D}(z_0, r)$ ,

$$g(z) = c_m + c_{m+1}(z - z_0) + c_{m+2}(z - z_0)^2 + \dots$$

which implies  $g \in H(\Omega)$ . Now  $g(z_0) = c_m \neq 0$ , so there exists a neighbourhood  $U_{z_0}$  of  $z_0$ , such that  $g \neq 0$  on  $U_{z_0}$ .

$\forall a \neq z_0 \in Z(f)$ , we have that  $g(a) = 0$  by definition of  $Z(f)$ , which implies that  $a \notin U_{z_0}$ , which contradicts that  $z_0 \in Z(f)^*$ . This implies  $f \equiv 0$  in  $\overline{D}(z_0, r)$ .

**Step 2:**  $Z(f)^0$  is both open and closed.

Note that

$$Z(f)^0 := \left\{ a \in Z(f) : \exists r > 0, \overline{D}(a, r) \subseteq Z(f) \right\}$$

is open by definition.

**WTP**  $[Z(f)^0]^* \subseteq [Z(f)]^*$ .

From **Step 1**, we know that  $[Z(f)^0]^* \subseteq Z(f)^0$ . Thus  $Z(f)^0$  contains its limit points and is hence closed by definition.

**Step 3:**  $Z(f) = \emptyset$  or  $\Omega$ .

$\Omega$  is connected

$$\implies \Omega = Z(f)^0 \sqcup \left( Z(f)^0 \right)^c$$

$$\implies \left( Z(f)^0 \right)^c \text{ is open and closed by Step 2}$$

A connected set cannot be expressed as a disjoint union of non-trivial open sets. Therefore, either  $Z(f)^0 = \emptyset$  or  $Z(f)^0 = \Omega$ .

$$Z(f)^0 = \emptyset \implies Z(f)^* = \emptyset \text{ by Step 1} \implies Z(f) = \emptyset$$

$$Z(f)^0 = \Omega \implies Z(f) = \Omega \text{ by Step 1}$$

□

### ✦ Corollary 21 (Uniqueness of a Function)

Let  $\Omega \subseteq \mathbb{C}$  be open and connected.  $\forall f, g \in H(\Omega)$  with  $f(z) = g(z)$  for  $z \in \Omega_1 \subseteq \Omega$  where  $\Omega_1$  has limit points. Then  $\forall z \in \Omega$ ,  $f(z) = g(z)$ .

** Proof**

Apply Lemma 19 to the function  $f - g$ .

**Remark**

1. In  $\mathbb{C}$ , we cannot have two functions sharing a region of points in their images. (But this is possible in  $\mathbb{R}$ )
2. Suppose  $f \in H(\Omega)$ ,  $\Omega \subseteq \mathbb{C}$  is open and connected,  $F \in H(\Omega')$  with  $\Omega \subseteq \Omega'$ . If  $f, F$  agree on  $\Omega$ , then  $F$  is called an analytic continuation of  $f$  in  $\Omega'$  (i.e.  $F$  'extends'  $f$  in  $\Omega'$ ). Lemma 19 states that  $F$  is uniquely determined by  $f$ , i.e. there is a unique way to analytically 'continue'  $f$ .

**17.2 Morera's Theorem****Remark (Recall)**

From Cauchy's Theorem, we know that  $\forall f \in H(\Omega) \implies \forall \gamma \in \Omega \int f = 0$ . We used Goursat's Theorem, i.e.  $\forall \Delta \in \Omega \int_{\Delta} f = 0$  to proof this, and in the process we constructed an antiderivative. Now, our question is, is the converse of the said Cauchy's Theorem true?

Unfortunately for us, that is not true (**example needed**). But a "partial" converse exists.

** Theorem 22 (Morera's Theorem)**

Let  $f$  be continuous on  $\Omega \subseteq \mathbb{C}$ , which is an open set, and  $\forall \Delta \in \Omega, \int_{\Delta} f = 0$ , where  $\Delta$  is a triangular path. Then  $f \in H(\Omega)$ .

** Proof**

Use the same construction as in Cauchy's Theorem for Convex Sets to get an antiderivative  $F$  for  $f$ , where  $F \in H(\Omega)$ , i.e.

$$F(z) := \int_{[a,z]} f(z) dz$$

Then  $F'(z) = f(z)$ , which in turn implies that  $f \in H(\Omega)$  since  $F$  is  $\mathbb{C}$ -differentiable on  $\Omega$  by  Theorem 17.



# 18 Lecture 18 Feb 28th 2018

## 18.1 Winding Numbers

Recall Cauchy's Integral Formula. We claimed that

$$\text{Ind}_{\mathbb{C}}(w) = \begin{cases} 1 & w \in \mathbb{C}^0 \\ 0 & w \notin \mathbb{C}^0 \end{cases}$$

We will now formally define this index.

---

### Definition 21 (Winding Numbers)

Let  $\gamma : [a, b] \rightarrow \mathbb{C}$  be a closed and oriented anti-clockwise, and  $\gamma^*$  be the image of  $\gamma$  in  $\mathbb{C}$ . Let  $\Omega = \mathbb{C} \setminus \gamma^*$ .  $\forall w \in \Omega$ , define the index of  $w$  with respect to  $\gamma$  as

$$\frac{1}{2\pi i} \int_{\gamma} \frac{dz}{z - w}$$

in which shall be called the winding number of  $\gamma$  around  $w$ .

---

### Theorem 23 (Winding Number Theorem)

We shall use notation as the definition above.  $\text{Ind}_{\gamma}(w)$  is

1. always an integer;
  2. constant on any connected component of  $\Omega$ ; and
  3. zero on the unbounded component of  $\Omega$ .
- 
-

### “ Note

$\gamma$  is compact in  $\mathbb{C}$  (since it creates a ring from  $[a, b]$  under  $\gamma$ ). So for some disc  $D$ ,  $\gamma^* \subseteq D$ . Let  $\Omega \supset \mathbb{C} \setminus D$ , where we note that the contained set is connected and unbounded. Then  $\Omega$  contains one unbounded component, while other components of  $\Omega$  are inside  $D$ . Therefore, we know that components in  $D$  are bounded.

### Proof

1. By definition,

$$\begin{aligned} \text{Ind}_\gamma(w) &= \frac{1}{2\pi i} \int_\gamma \frac{dz}{z-w} \\ &= \frac{1}{2\pi i} \int_a^b \frac{\gamma'(t) dt}{\gamma(t)-w} \end{aligned}$$

**WTS**  $\text{Ind}_\gamma(w) \in \mathbb{Z} \equiv \int_a^b \frac{\gamma'(t) dt}{\gamma(t)-w} \in 2\pi i\mathbb{Z}$ .

Note that  $z \in 2\pi i\mathbb{Z} \iff e^z = 1$ . Thus it suffices to show that

$$e^{\int_a^b \frac{\gamma'(t) dt}{\gamma(t)-w}} = 1$$

**Idea:** Think of  $\exp\left(\int_a^u \frac{\gamma'(t) dt}{\gamma(t)-w}\right)$  as a function of  $u$ , call it  $\phi(u)$ . Then we just need to show that  $\phi(b) = 1$ . We know that  $\phi(a) = \exp\left(\int_a^a \dots\right) = 1$ . This motivates us to find the derivative of  $\phi$ .

Define  $\phi$  accordingly, and then since  $(e^{f(u)})' = e^{f(u)} \cdot f'(u)$ ,

$$\begin{aligned} \phi'(u) &= \phi(u) \cdot \frac{d}{du} \int_a^u \frac{\gamma'(t) dt}{\gamma(t)-w} \\ \text{by FTC} \implies \frac{\phi'(u)}{\phi(u)} &= \frac{\gamma'(u)}{\gamma(u)-w} \\ \implies \phi'(u) (\gamma(u)-w) - \gamma'(u)\phi(u) &= 0 \\ \implies \frac{d}{du} \left( \frac{\phi(u)}{\gamma(u)-w} \right) &= 0 \quad \text{by quotient rule} \\ \implies \frac{\phi(b)}{\gamma(b)-w} &= \frac{\phi(a)}{\gamma(a)-w} \quad \text{since } \frac{\phi(u)}{\gamma(u)-w} \text{ is a constant function of } u \\ \implies \phi(b) = \phi(a) = 1 &\quad \because \gamma \text{ is closed.} \end{aligned}$$



We will prove that  $\text{Ind}_\gamma(w)$  is continuous.

$$\begin{aligned} \forall w \in \Omega \forall z \in \gamma^* \exists M > 0 \quad |w - z| > M \\ \forall \varepsilon > 0 \exists \delta = \frac{M^2 \pi \varepsilon}{\int_\gamma dz} > 0 \forall w_0 \in \Omega \\ |w - w_0| < \delta \wedge |w_0 - z| > \frac{M}{2} \end{aligned}$$

then

$$\begin{aligned} |\text{Ind}_\gamma(w) - \text{Ind}_\gamma(w_0)| &= \left| \frac{1}{2\pi i} \int_\gamma \frac{dz}{z - w} - \frac{1}{2\pi i} \int_\gamma \frac{dz}{z - w_0} \right| \\ &= \frac{1}{2\pi} \left| \int_\gamma \frac{w - w_0}{(z - w)(z - w_0)} dz \right| \\ &\leq \frac{1}{2\pi} \int_\gamma \left| \frac{w - w_0}{(z - w)(z - w_0)} \right| dz \\ &< \frac{1}{2\pi} \delta \int_\gamma \left| \frac{2}{M \cdot M} \right| dz \\ &= \frac{1}{M^2 \pi} \delta \int_\gamma dz = \varepsilon \end{aligned}$$

2. Also  $\text{Ind}_\gamma(w)$  takes only integer values, thus it must be constant on each open connected component<sup>1</sup> (*why?*).

<sup>1</sup> We may invoke Lemma 19 but it is, to an extent, unnecessary for such a powerful statement.

3. Note that

$$|\text{Ind}_\gamma(w)| = \frac{1}{2\pi} \left| \int_a^b \frac{\gamma'(t) dt}{\gamma(t) - w} \right|$$

Let  $w$  be in the unbounded component in the complement of  $\gamma$  such that  $|w| \rightarrow \infty$ . Then  $\forall t \in [a, b], \exists M > 0$  such that

$$\frac{1}{|\gamma(t) - w|} \leq \frac{1}{M}$$

which implies that

$$|\text{Ind}_\gamma(w)| \leq \frac{1}{2\pi} \frac{1}{M} \cdot \underbrace{\int_a^b |\gamma'(t)| dt}_{\text{is a fixed constant as } \gamma \text{ is a fixed path}}$$

$$\implies (|w| \rightarrow \infty \implies M \rightarrow \infty \implies |\text{Ind}_\gamma(w)| \rightarrow 0)$$

Then by parts 1 and 2, the proof is completed.  $\square$

**Remark**

Note that by 2, we have that  $\forall w \in \mathbb{C}^0$ ,

$$\frac{1}{2\pi i} \int_C \frac{dz}{z-w} = \frac{1}{2\pi i} \int_C \frac{dz}{z-z_0} = \frac{1}{2\pi i} \int_0^{2\pi} \frac{Rie^{i\theta}}{Re^{i\theta}} d\theta = 1$$

where  $z_0$  is the center of the circle path  $C$ .

## 19 Lecture 19 Mar 2nd 2018

### 19.1 Singularities

#### Exercise 19.1.1

Let  $C : [0, 2\pi] \rightarrow \mathbb{C}$  such that  $\forall t \in [0, 2\pi], t \rightarrow e^{it}$ . Suppose  $f \in H(\Omega)$ , then by Cauchy

$$\int_C f(z) dz = 0$$

Let  $f(z) = \frac{1}{z}$ , then  $\int_C \frac{1}{z} dz = 2\pi i \operatorname{Ind}_C(0) = 2\pi i$  when it is “supposed” to be 0 by the argument above. Then in this case,  $f \notin H(\Omega)$ . In fact,  $f$  is undefined at 0.

The example above introduces us to the study of such exceptional points.

---

#### Definition 22 (Isolated Singularity)

$\forall a \in \mathbb{C}, \exists r > 0, \exists D = D(a, r)$ .

$$f \in H(D \setminus \{a\}) \wedge f(a) \text{ is undefined} \iff$$

$f$  has a(n) *point/isolated singularity* at  $z = a$ .

---

#### Example 19.1.1

1. Given  $f \in H(\mathbb{C} \setminus \{0\})$ , define  $f(z) = \frac{e^z - 1}{z}$ . Clearly,  $z$  is a singularity. Consider the function  $(e^z - 1) \in H(\mathbb{C})$ . Then we have that the function has a power series expansion around  $z = 0$ . So  $\forall z \in \mathbb{C}$ ,

$$e^z - 1 = z + \frac{z^2}{2!} + \frac{z^3}{3!} + \dots$$

And for  $z \neq 0$ , we have

$$\frac{e^z - 1}{z} = 1 + \frac{z}{2!} + \frac{z^2}{3!} + \dots \quad (19.1)$$

This motivates us to define

$$g(z) = \begin{cases} \frac{e^z - 1}{z} & z \in \mathbb{C} \setminus \{0\} \\ 1 & z = 0 \end{cases}$$

Clearly then  $g \in H(\mathbb{C})$ , where in  $\mathbb{C} \setminus \{0\}$  its holomorphicity is given by  $f$ , and in a neighbourhood of 0, from Equation (19.1). Therefore, by assigning  $f$  the value of 1 at  $z = 0$ , we can make  $f$  "entire".

We call such a point  $z$  as a **removable singularity** for  $f$ .

2. Given  $f \in H(\mathbb{C} \setminus \{0\})$ , define  $f(z) = \frac{1}{z}$ . Is the singularity at 0 removable?

Suppose  $\exists g \in H(\mathbb{C})$  such that

$$\forall z \in \mathbb{C} \setminus \{0\} \quad g(z) = f(z) \quad (19.2)$$

$\therefore \exists r > 0 \forall z \in D(0, r)$

$$g(z) = c_0 + c_1z + c_2z^2 + \dots \quad (19.3)$$

Consider the function  $zg(z)$ . By Equation (19.2),

$$\forall z \in \mathbb{C} \setminus \{0\} \quad zg(z) = 1$$

By Equation (19.3),  $z = 0 \implies zg(z) = 0$ . But this cannot happen since  $zg(z) \in H(\mathbb{C})$  (if we pick an open ball of, say,  $\frac{1}{2}$  around 0, then there are no points in the entirety of  $\mathbb{C}$  that is close to 0).

Therefore  $z = 0$  is not a removable singularity for  $f$ .

### Definition 23 (Removable Singularity, Pole, Essential Singularity)

Let  $f$  have a singularity at  $z_0 \in \mathbb{C}$ .

1.  $\exists r > 0 \forall z \in D = D(z_0, r) \exists g(z) \in H(D) \forall z \in D \setminus \{z_0\} g(z) = f(z)$   
 $\implies f$  has a **removable singularity** at  $z_0$ <sup>1</sup>.

<sup>1</sup> For the laymen, "the value of  $f$  at  $z_0$  can be corrected or defined to make it holomorphic in its designated region."

2.  $\exists r > 0 \forall z \in D = D * (z_0, r) \exists A, B \in H(D) A(z_0) \neq 0 \wedge B(z_0) = 0$   
 $f(z) = \frac{A(z)}{B(z)}$   
 $\implies f$  has a **pole** at  $z_0$  (a non-removable singularity)<sup>2</sup>
3.  $f$  has a singularity at  $z_0$  which is neither removable nor a pole  $\implies$   
 $f$  has an **essential singularity** at  $z_0$ .

<sup>2</sup>For the laymen, "the singularity of  $f$  comes from a zero of its denominator."

**Example 19.1.2**

To show an example of an essential singularity, consider the function  $f(z) = e^{\frac{1}{z}}$ . If we attempt to do a "Taylor expansion" on the function (which is invalid at  $z = 0$ ), we have

$$f(z) = 1 + \frac{1}{z} + \frac{1}{2!z^2} + \frac{1}{3!z^3} + \dots$$

The point 0 for  $f$  is said to be a "pole of infinite order" (this shall be defined later on)

While **removable singularities** are nice to have, they are not as interesting to us. On the other hand, we are more interested in their non-removable counterpart, the **poles**. This motivates the study of zeros of holomorphic functions.

 **Theorem 24 (Theorem 9)**

Let  $\Omega \subseteq \mathbb{C}$  be open and connected. Suppose that  $f \in H(\Omega)$  with  $f \not\equiv 0$  on  $\Omega$  and that  $f$  has a zero at  $z_0 \in \Omega$ . Then

$$\begin{aligned} \exists r > 0 \forall z \in D = D(z_0, r) \exists g \in H(D) g(z_0) \neq 0 \exists ! n \in \mathbb{N} \\ f(z) = (z - z_0)^n \cdot g(z) \end{aligned} \tag{19.4}$$

 **Proof**

By *Analytic Continuation*, zeros of  $f$  are isolated since  $f \not\equiv 0$ . So  $\exists r > 0$  such that  $\exists D = D(z_0, r)$ , in which  $\forall z \in D \setminus \{z_0\}, f(z) \neq 0$ .

Since  $f \in H(\Omega), \forall z \in D,$

$$f(z) = \sum_{k=0}^{\infty} c_k(z - z_0)^k$$

As  $f \not\equiv 0$  in  $D$ ,  $\exists n \in \mathbb{N} \setminus \{0\}$  that is the smallest such that  $c_n \neq 0$ .

<sup>3</sup>  $n \neq 0$  since we have  $f(z_0) = 0$  which implies  $c_0 = 0$ .

$$\begin{aligned} \therefore f(z) &= c_n(z - z_0)^n + c_{n+1}(z - z_0)^{n+1} + \dots \\ &= (z - z_0)^n \underbrace{[c_n + c_{n+1}(z - z_0) + \dots]}_{\text{call this } g(z)} \end{aligned}$$

Note that  $g(z_0) \neq 0$  since  $c_n \neq 0$ . Thus  $g(z) \in H(D)$  since it has the same radius of convergence as  $f$ .

To prove uniqueness, suppose that we may write

$$f(z) = \sum_{k=0}^{\infty} (z - z_0)^k \cdot g(z) = (z - z_0)^m \cdot h(z)$$

for some  $m \in \mathbb{N}$  and that  $h(z) \neq 0$ . If  $m > n$ , dividing both sides by  $(z - z_0)^n$ ,

$$g(z) = (z - z_0)^{m-n} h(z).$$

As  $z \rightarrow z_0$ , we would have  $g(z_0) = 0$ , which is a contradiction. If  $m < n$ , we can perform a similar argument and have that as  $z \rightarrow z_0$ ,  $h(z_0) = 0$ , also a contradiction. Therefore,  $m = n$  and  $h = g$ .  $\square$

We say that  $f$  has a **zero of order  $n$**  at  $z_0$  if Equation (19.4) holds.

## 20 Lecture 20 Mar 5th 2018

### 20.1 Singularity (Continued)

Recall the definition of a **removable singularity** from  Definition 23.

---

#### Theorem 25 (Theorem 10)

If  $f \in H(\Omega \setminus \{z_0\})$  has an isolated singularity at  $z_0$  and  $\lim_{z \rightarrow z_0} (z - z_0)f(z) = 0$ , then the singularity at  $z_0$  is removable.

---

#### Proof

Since  $f(z_0)$  is undefined, set

$$h(z) = \begin{cases} (z - z_0)^2 f(z) & \forall z \in \Omega \setminus \{z_0\} \\ 0 & z = z_0 \end{cases}$$

Clearly  $h \in H(\Omega \setminus \{z_0\})$ . At  $z_0$ ,

$$\begin{aligned} \lim_{z \rightarrow z_0} \frac{h(z) - h(z_0)}{z - z_0} &= \lim_{z \rightarrow z_0} \frac{(z - z_0)^2 f(z)}{z - z_0} \quad \text{1} \\ &= 0 \text{ by assumption} \end{aligned}$$

<sup>1</sup> Goes to show that the definition of  $h$  is no foresight.

$\therefore h'(z_0)$  exists and equals 0. Clearly then that  $h \in H(\Omega)$ . So  $\exists r > 0$  such that  $\exists D = D(z_0, r)$ , so that  $\forall z \in D$ ,

$$h(z) = c_0 + c_1(z - z_0) + c_2(z - z_0)^2 + \dots$$

But  $c_0 = h(z_0) = 0$  and  $c_1 = h'(z_0) = 0$ . Thus the power series can be

written as

$$\begin{aligned} h(z) &= c_2(z - z_0)^2 + c_3(z - z_0)^3 + \dots \\ &= (z - z_0)^2 [c_2 + c_3(z - z_0) + \dots] \end{aligned}$$

Hence by the definition of  $h$ ,  $\forall z \in \Omega \setminus \{z_0\}$ ,  $f(z) = c_2 + c_3(z - z_0) + \dots$ . Therefore, by redefining  $f(z_0) = c_2$ , we see that the singularity at  $z_0$  is removable.

We may also complete the proof by defining a function  $g$  as,  $\forall z \in \Omega$ ,

$$g(z) = \begin{cases} f(z) & z \neq z_0 \\ c_2 & z = z_0 \end{cases}$$

□

### Recall Theorem 24

Let  $\Omega \subseteq \mathbb{C}$  be open and connected, and  $f \in H(\Omega)$  where  $\forall z \in \Omega$ ,  $f(z) \neq 0$ .

$$f(z_0) = 0 \implies$$

$$\begin{aligned} \exists r > 0 \quad \exists D = D(z_0, r) \quad \forall z \in D \quad \exists! n \in \mathbb{N} \\ \exists! g \in H(D) \quad g(z_0) \neq 0 \\ f(z) = (z - z_0)^n g(z) \end{aligned}$$

### Definition 24 (Zero of Order $n$ & Simple Zero)

By the above setting, we say that  $f$  has a **zero of order  $n$**  at  $z_0$ .<sup>2</sup>

If  $n = 1$ , we say that  $z_0$  is a **simple zero**.

<sup>2</sup> In laymen terms, "Rate at which the function vanishes at  $z_0$ . The greater  $n$  is, the greater the rate."

### Recall definition of a pole from Definition 23

Suppose  $f$  has an isolated singularity at  $z_0$ , and that there exists a neighbourhood  $D$  around  $z_0$  where  $A, B \in H(D)$ , in which  $A$  and  $B$  are defined such that  $\forall z \neq z_0 \in D$ ,  $A(z_0) \neq 0 \wedge B(z_0) = 0$ , so that we can let  $f(z) = \frac{A(z)}{B(z)}$ . Then  $f$  has a pole at  $z_0$ .



### Theorem 26 (Theorem 9.1)

Stein & Shakarchi - Complex Analysis (pg. 74)

If  $f$  has a pole at  $z_0 \in \Omega$ , then in a neighbourhood of that point there exists a non-vanishing holomorphic function  $h$  and a unique positive integer  $n$  such that

$$f(z) = (z - z_0)^{-n}h(z)$$

#### Proof

By  Theorem 24, we have  $\frac{1}{f(z)} = (z - z_0)^n g(z)$ , where  $g$  is holomorphic and non-vanishing in a neighbourhood of  $z_0$ , so the result follows with  $h(z) = \frac{1}{g(z)}$ .  $\square$

### Definition 25 (Pole of order $n$ & Simple Pole)

With the above setting, we say that  $f$  has a **pole of order  $n$**  at  $z_0$  if the function  $B$  has a zero of order  $n^3$

If  $n = 1$ , then  $z_0$  is a simple pole.

<sup>3</sup> In laymen terms, "Rate at which  $f$  'grows' near  $z_0$ ."

### Theorem 27 (Theorem 11)

Let  $f$  have a pole of order  $n$  at  $z_0$ . Then  $\exists r > 0$ ,  $\exists D = D(z_0, r)$ , such that  $\forall z \in D \setminus \{z_0\}$ ,

$$f(z) = \frac{c_{-n}}{(z - z_0)^n} + \frac{c_{-(n-1)}}{(z - z_0)^{n-1}} + \dots + \frac{c_{-1}}{z - z_0} + G(z)$$

for some  $G \in H(D)$ .

#### Proof

By  Theorem 26, write the holomorphic function  $h$  as  $h(z) = a_0 + a_1(z - z_0) + a_2(z - z_0)^2 + \dots$ , then

$$f(z) = \frac{1}{(z - z_0)^n} \left[ a_0 + a_1(z - z_0) + a_2(z - z_0)^2 + \dots \right].$$

The proof is complete by expanding the equation.  $\square$

---

---

 **Definition 26 (Principal Part)**

In  *Theorem 27*, the sum  $\sum_{j=1}^n \frac{c_{-j}}{(z-z_0)^j}$  is called the **principal part** of  $f$  at the pole  $z_0$ .

---

---

 **Definition 27 (Residue)**

In  *Theorem 27*, the coefficient  $c_{-1}$  is called the **residue** of  $f$  at the pole  $z_0$ , denoted  $\operatorname{Res}_{z=z_0} f(z)$ .

---

The **residue** shall be more carefully studied later on.

## 21 Lecture 21 Mar 7th 2018

### 21.1 Singularity (Continued 2)

#### Theorem 28 (Casorati-Weierstrass)

Let  $z_0 \in \Omega$  and  $f \in H(\Omega \setminus \{z_0\})$ . Suppose  $f$  has a singularity at  $z_0$ . Then one of the following occurs:

1.  $f$  is a removable singularity at  $z_0$ ;
2.  $\exists m \in \mathbb{N}$ ,  $\{c_j\}_{j=1}^m \subseteq \mathbb{C}$ ,  $f(z) - \sum_{j=1}^m c_j(z - z_0)^{-j}$  has a removable singularity at  $z_0$ ; or
3.  $\forall r > 0$ ,  $B(z_0, r) \subseteq \Omega$  such that  $f(B^0(z_0, r))$  is dense in  $\mathbb{C}$ .<sup>1</sup>

<sup>1</sup>  $B^0(z_0, r)$  is the punctured ball.

#### Proof

Suppose 3. does not hold, i.e.  $f(B^0(z_0, r))$  is not dense in  $\mathbb{C}$  for some  $r > 0$ . Then  $\exists w \in \mathbb{C}$ ,  $\exists \delta > 0$ , such that

$$\begin{aligned} f(B^0(z_0, r)) \cap B(w, \delta) &= \emptyset \\ \implies \forall z \in B^0(z_0, r) \quad |f(z) - w| &> \delta \end{aligned}$$

Consider  $g(z) = \frac{1}{f(z) - w}$  for  $z \in B^0(z_0, r)$ , in which  $g \in H(B^0(z_0, r))$ . Then  $|g(z)| \leq \frac{1}{\delta}$  for all  $z \in B^0(z_0, r)$ , which implies that

Plausible since  $f(z) - w \neq 0$ .

$$\lim_{z \rightarrow z_0} (z - z_0)g(z) = 0$$

Squeeze Theorem

By  Theorem 25,  $g$  has a removable singularity at  $z_0$ , thus we can extend the function to a function  $\tilde{g} \in H(B(z_0, r))$ . From here, we try to construct a function that extends on  $f$  onto the singularity  $z_0$ , say,  $\tilde{f}$ . The



$\therefore \forall z \in B^0(z_0, r_1),$

$$f(z) - \frac{a_0}{(z - z_0)^m} - \dots - \frac{a_{m-1}}{z - z_0} = w + a_m + a_{m+1}(z - z_0) \dots$$

Thus we may define an "extended" function of  $f$ ,  $\tilde{f}$  to be  $w + a_m$  at the singularity  $z_0$ . Therefore,  $f(z) - \sum_{j=1}^m a_j(z - z_0)^{-j}$  has a removable singularity at  $z_0$ , i.e. 2. holds.  $\square$

---



## 22 Lecture 22 Mar 9th 2018

### 22.1 Singularity (Continued 3)

---

#### ✦ Corollary 29

If  $f$  has an essential singularity at  $z_0$  and is holomorphic in some  $B^0(z_0, r)$  where  $r > 0$ , then  $f(B^0(z_0, r))$  is dense in  $\mathbb{C}$ .

---

#### ✎ Proof

Suppose not, i.e. 3. of  Theorem 28 does not hold. Then either 1., which implies that  $z_0$  is removable, or 2., which implies that  $z_0$  is a pole, is true. This contradicts the assumption that  $z_0$  is an essential singularity.  $\square$

---

#### Remark

There are a lot more that are actually true from  Theorem 28! **Picard** showed that in any such punctured ball  $B^0(z_0, r)$  around the essential singularity  $z_0$ ,  $f$  takes on every complex value (except possibly one value) infinitely often.

### 22.2 The Residue Theorem

---

#### “ Note (Recall)

If  $f$  has a pole at  $z_0$ ,  $f \in H(\Omega \setminus \{z_0\})$ , then in some open neighbourhood

$D$  of  $z_0$ , we can write  $\forall z \in D \setminus \{z_0\}$

$$f(z) = \underbrace{\frac{c_{-k}}{(z-z_0)^k} + \dots + \frac{c_{-1}}{(z-z_0)}}_{\text{Principal Part}} + \underbrace{c_0 + c_1(z-z_0) + \dots}_{G(z)} \quad (22.1)$$

with  $G \in H(D)$ .

### Theorem 30 (Cauchy's Residue Theorem)

Let  $\Omega \subseteq \mathbb{C}$  be open,  $f \in H(\Omega \setminus \{z_0\})$  where  $z_0 \in \Omega$  is a pole. If  $\gamma$  is a closed path in  $\Omega \setminus \{z_0\}$  such that  $\forall w \notin \Omega$ ,  $\text{Ind}_\gamma(w) = 0$ . Then

$$\frac{1}{2\pi i} \int_\gamma f(z) dz = \left( \text{Res}_{z=z_0} f(z) \right) \text{Ind}_\gamma(z_0)$$

where  $\text{Ind}_\gamma(z_0) := \frac{1}{2\pi i} \int_\gamma \frac{1}{z-z_0} dz$ .

### Proof

Using notation of Equation (21.1), define  $g(z)$  such that

$$g(z) := \begin{cases} f(z) - \sum_{j=1}^k \frac{c_{-j}}{(z-z_0)^j} & z \in \Omega \setminus \{z_0\} \\ c_0 & z = z_0 \end{cases}$$

Clearly,  $g \in H(\Omega \setminus \{z_0\})$ , since  $f(z)$  minus finitely many polynomials with non-zero denominators is still a holomorphic function. At  $z_0$ , with a neighbourhood  $D$  around the point, we have, from Equation (21.1),

$$g(z) = c_0 + c_1(z-z_0) + \dots$$

which  $g(z_0)$  agrees with  $c_0$  and for any point  $z \in D \setminus \{z_0\}$ , by definition of  $g$  using Equation (21.1). This implies that  $g \in H(D) \implies g \in H(\Omega)$ .

Thus, by Cauchy's Theorem,

$$\int_\gamma g(z) dz = 0$$



Then  $\forall z \in \gamma$  and since  $z_0 \notin \gamma$ , we get

$$\int_{\gamma} f(z) dz = \int_{\gamma} \sum_{j=1}^k \frac{c_{-j}}{(z-z_0)^j} dz$$

Consider each term of RHS in turn. Note that for  $m \geq 2$ , since  $\frac{-1}{(m-1)(z-z_0)^{m-1}}$  is the antiderivative of  $\frac{1}{(z-z_0)^m}$ ,

$$\begin{aligned} \int_{\gamma} \frac{1}{(z-z_0)^m} dz &= F(\gamma(b)) - F(\gamma(a)) \quad \text{by FTC} \\ &= 0 \quad \text{since } \gamma \text{ is closed.} \end{aligned}$$

If  $m = 1$ , then

$$\frac{1}{2\pi i} \int_{\gamma} \frac{1}{z-z_0} dz = \text{Ind}_{\gamma}(z_0) \quad \text{by definition}$$

$$\begin{aligned} \therefore \frac{1}{2\pi i} \int_{\gamma} f(z) dz &= c_{-1} \text{Ind}_{\gamma}(z_0) \\ &= \left( \text{Res}_{z=z_0} f(z) \right) \text{Ind}_{\gamma}(z_0) \end{aligned}$$

□

### Definition 28 (Meromorphic Functions)

A function  $f$  is said to be meromorphic on  $\Omega$  if  $\exists \mathcal{A} \subseteq \Omega$  such that

1.  $\mathcal{A}^* = \emptyset$
2.  $f \in H(\Omega \setminus \mathcal{A})$
3.  $\forall z \in \mathcal{A}$   $f$  has a pole of finite order on  $z$ .

### Remark

Holomorphicity  $\subseteq$  Meromorphicity (let  $\mathcal{A} = \emptyset$ )



## 23 Lecture 23 Mar 12th 2018

### 23.1 The Residue Theorem (Continued)

We can generalize  Theorem 30 for when there are more than one pole.

---

#### Theorem 31 (Cauchy's Residue Theorem - Generalized)

Let  $\Omega \subseteq \mathbb{C}$  be open,  $f$  be meromorphic on  $\Omega$ ,  $\mathcal{A}$  be a set of poles. If  $\gamma$  is a closed path in  $\Omega \setminus \mathcal{A}$  such that  $\forall w \notin \Omega \text{ Ind}_\gamma(w) = 0$ , then

$$\frac{1}{2\pi i} \int_\gamma f(z) dz = \underbrace{\sum_{a \in \mathcal{A}} (\text{Res}_{z=a} f(z)) \text{Ind}_\gamma(a)}_{\text{this is a finite sum}} \quad (23.1)$$

---

#### Proof

We will first need to prove that  $\mathcal{A}$  has only finitely many points.

Since  $f$  is meromorphic, the set of poles,  $\mathcal{A}$ , must not contain its limit points by definition of meromorphisms, i.e. each of the poles are isolated singularities and  $\mathcal{A}^* = \emptyset$ . Let  $\mathcal{A}' := \{a \in \mathcal{A} : \text{Ind}_\gamma(a) \neq 0\}$ . Suppose, for contradiction, that  $\mathcal{A}'$  has infinitely many points. Since the union of  $\gamma$  and its interior is compact, by Bolzano-Weierstrass, any infinite subset (subsequence, to be exact, but we may simply index the points in the subset) must converge to a point in the union of  $\gamma$  and its interior, call it  $w$ . Since  $\mathcal{A}'$  is a subset (subsequence) of the union of  $\gamma$  and its interior,  $\mathcal{A}'$  converges to  $w$ . Now since  $|f(z)| \rightarrow \infty$  and  $z \rightarrow a$  for all  $a \in \mathcal{A}'$ , and since  $f$  is continuous since it is meromorphic and hence holomorphic, we have that  $|f(z)| \rightarrow \infty$  as  $z \rightarrow w$ . Hence  $w$  is a pole in the interior of  $\gamma$  and is hence in  $\mathcal{A}'$ . In other words,  $\mathcal{A}'$  contains

its limit points, which contradicts the fact that  $\mathcal{A}' \subseteq \mathcal{A}$  does not contain its limit points. Therefore, there are only finitely many points in  $\mathcal{A}'$ .

It remains to prove Equation (23.1).

Since  $\mathcal{A}$  is finite, let  $|\mathcal{A}| = n$  for some  $n \in \mathbb{N}$ . For any  $a, b \in \mathbb{N}$ ,  $\forall z_a, z_b \in \mathcal{A}$ ,  $\exists r_a, r_b > 0$  such that  $z_b \notin D(z_a, r_a) \wedge z_a \notin D(z_b, r_b)$ . Therefore,  $\forall l \in \mathbb{N}$ ,  $\forall z_l \in \mathcal{A}$ , we can write,  $\forall z \in D(z_l, r_l)$ , that

$$f(z) = \frac{c_{l,-k_l}}{(z-z_l)^{k_l}} + \dots + \frac{c_{l,-1}}{z-z_l} + c_{l,0} + c_{l,1}(z-z_l) + \dots, \quad (23.2)$$

where  $k_l$  is the order of the pole  $z_l$ . Since we are only concerned with the poles in the interior of  $\gamma$ , let  $\mathcal{A}' := \{a \in \mathcal{A} : \text{Ind}_\gamma(a) = 1\} = \{z_1, z_2, \dots, z_n\}$ .

Consider the function

$$g(z) = \begin{cases} f(z) - \sum_{l=1}^n \sum_{j=1}^{k_l} \frac{c_{l,-j}}{(z-z_l)^j} & \forall z \in \Omega \setminus \mathcal{A}' \\ c_{l,0} - \sum_{\substack{m=1 \\ m \neq l}}^n \sum_{j=1}^{k_m} \frac{c_{m,-j}}{(z-z_m)^j} & z \in \mathcal{A}' \end{cases}$$

At the neighbourhood of each  $z_l \in \mathcal{A}'$  save  $z_l$  itself, that is in  $D(z_l, r_l) \setminus \{z_l\}$  where  $D(z_l, r_l)$  is as defined above, we have that

$$g(z) = \underbrace{f(z) - \sum_{j=1}^{k_l} \frac{c_{l,-j}}{(z-z_l)^j}}_{A_{z,l}} - \underbrace{\sum_{\substack{m=1 \\ m \neq l}}^n \sum_{j=1}^{k_m} \frac{c_{m,-j}}{(z-z_m)^j}}_{B_{z,l}} \quad (23.3)$$

in which we observe that  $A_{z,l}$  is holomorphic by Casorati-Weierstrass, and  $B_{z,l}$  is holomorphic in  $D(z_l, r_l) \setminus \{z_l\}$  since  $\forall z \in D(z_l, r_l) \setminus \{z_l\}$ ,  $z \notin \mathcal{A}'$  and hence the denominators cannot be zero. Thus  $g \in H(D(z_l, r_l))$ .

At  $z_l$ ,  $g(z_l)$  agrees with Equation (23.3) by Equation (23.2). Thus  $g \in H(D(z_l, r_l))$ .

Then by Cauchy's Theorem,

$$\int_\gamma g(z) dz = 0.$$

Then,  $\forall z \in \gamma^*$  (image of  $\gamma$ ), since  $\mathcal{A} \cap \gamma^* = \emptyset$  (since  $\gamma^* \in \Omega \setminus \mathcal{A}$ ), we get

$$\int_\gamma f(z) dz = \int_\gamma \sum_{l=1}^n \sum_{j=1}^{k_l} \frac{c_{l,-j}}{(z-z_l)^j} dz$$

For each of the terms in  $\sum_{j=1}^{k_l} \frac{c_{l,-j}}{(z-z_l)^j}$ , for  $j \geq 2$ , we have that the antiderivative of  $\frac{1}{(z-z_l)^j}$  is  $-\frac{1}{(j-1)(z-z_l)^{j-1}}$ . Thus by the Fundamental Theorem of Calculus, since we are integrating over the closed path  $\gamma$ , the integral of these terms are 0. When  $j = 1$ , since  $\frac{1}{2\pi i} \int_{\gamma} \frac{1}{z-z_l} = \text{Ind}_{\gamma}(z_l)$ , we have that

$$\begin{aligned} \frac{1}{2\pi i} \int_{\gamma} f(z) dz &= \sum_{l=1}^n c_{l,-1} \text{Ind}_{\gamma}(z_l) \\ &= \sum_{l=1}^n \left( \text{Res}_{z=z_l} f(z) \right) \text{Ind}_{\gamma}(z_l) \end{aligned}$$

as required.

Another proof that we can be shown is as follows:

Using similar notations as above, on each of the neighbourhood of the points in  $\mathcal{A}$ , we define a keyhole-like path around the points, with a circular path  $\gamma_l$ , oriented in the opposite direction of  $\gamma$ , of radius  $r_l \geq \varepsilon_l > 0$  centered around each  $z_l$ , connected to the path  $\gamma$  through a corridor of width  $\delta_l$ . This construction is similar to the proof of Cauchy's Integral Formula in our lectures, where we extend the path of  $\gamma$  inwards so as to avoid the poles. As each  $\delta_l \rightarrow 0$ , we have

$$\int_{\gamma} f(z) dz = \sum_{l=1}^n \int_{\gamma_l} f(z) dz = \sum_{l=1}^n \int_{\gamma_l} \sum_{j=-k_l}^{\infty} c_{l,j} (z-z_l)^j dz$$

Now for  $-k_l \leq j \leq 2$ , the term  $c_{l,j} (z-z_l)^j$  have antiderivatives as described above, and are thus 0 by FTC, on the path  $\gamma_l$ . When  $j \geq 0$ ,  $\sum_{j=0}^{\infty} c_{l,j} (z-z_l)^j$  is a holomorphic function by construction, and hence their integrals are 0 by Cauchy's Theorem. We are, therefore, left with

$$\int_{\gamma} f(z) dz = \sum_{l=1}^n \int_{\gamma_l} \frac{c_{l,-1}}{z-z_l} dz$$

which in turn implies

$$\frac{1}{2\pi i} \int_{\gamma} f(z) dz = \sum_{l=1}^n \left( \text{Res}_{z=z_l} f(z) \right) \text{Ind}_{\gamma_l}(z_l)$$

This implies the desired result (through a similar proof given in  Theorem 30).

□

### Remark

We need  $\Omega$  to be connected with the interior of  $\gamma$  contained in  $\Omega$ , i.e.  $\Omega$  is

simply connected.

Now all the above begs the question: how exactly do we find the residue of a pole?

Suppose that  $f$  has a pole of order  $k$  at  $z_0$ . Then in some neighbourhood  $D$  of  $z_0$ , we have the Laurent expansion

$$f(z) = \frac{a_{-k}}{(z-z_0)^k} + \dots + \frac{a_{-1}}{z-z_0} + a_0 + a_1(z-z_0) + \dots$$

which implies

$$f(z)(z-z_0)^k = a_{-k} + a_{-k+1}(z-z_0) + \dots + a_{-1}(z-z_0)^{k-1} + \dots$$

So  $a_{-1}$  is the  $(k-1)^{\text{th}}$  coefficient for  $f(z)(z-z_0)^k$ , i.e. we can get

$$\operatorname{Res}_{z=z_0} f(z) = a_{-1} = \lim_{z \rightarrow z_0} \frac{1}{(k-1)!} \frac{d^{k-1}}{dz^{k-1}} f(z)(z-z_0)^k$$

## 23.2 Applications of Cauchy's Residue Theorem

### Exercise 23.2.1

Evaluate  $\int_{-\infty}^{\infty} \frac{1}{1+x^4} dx$ .

The typical approach (from a complex analysis standpoint) is:

1. Choose a complex function and integrate along some path / contour  $\gamma$ . By the Residue Theorem, we can get our answer in a straightforward way.
2. Break the contour into different parts
  - the needed real integral
  - use symmetry, decay of function, etc., in the limit (**we shall see more about this later on**)

Let  $f(z) = \frac{1}{1+z^4}$ . The singularities are

$$z^4 = -1 \implies z = e^{i\frac{\pi}{4}}, e^{i\frac{3\pi}{4}}, e^{i\frac{5\pi}{4}}, e^{i\frac{7\pi}{4}}$$

(Note: These are all simple poles)

Let  $R > 0$ , and let  $\Gamma_R$  be the semi-circular, anti-clockwise contour, centered at zero, sitting in the positive side of the imaginary axis on the







## 24 Lecture 24 Mar 14 2018

### 24.1 Application of Cauchy's Residue Theorem (Continued)

We will continue with the previous example.

#### Exercise 24.1.1

Evaluate  $I = \int_{-\infty}^{\infty} \frac{1}{1+x^4} dx$ .

Consider the function  $f(z) = \frac{1}{1+z^4}$ . Then  $f$  has simple poles at  $\alpha_1 = e^{i\frac{\pi}{4}}$ ,  $\alpha_2 = e^{i\frac{3\pi}{4}}$ ,  $\alpha_3 = e^{i\frac{5\pi}{4}}$ ,  $\alpha_4 = e^{i\frac{7\pi}{4}}$ . Consider the contour  $\Gamma_R$ , where  $R$  is large, that consists of an anticlockwise semi-circle  $C_R$  going from  $R$  to  $-R$ , and a straight line from  $-R$  to  $R$  on the real axis.

By the Residue Theorem,

$$\frac{1}{2\pi i} \int_{\gamma} \frac{1}{1+z^4} dz = \operatorname{Res}_{z=\alpha_1} f(z) + \operatorname{Res}_{z=\alpha_2} f(z) \quad (24.1)$$

Note that for Equation (24.1),

$$\text{LHS} = \frac{1}{2\pi i} \left[ \int_{-R}^R \frac{1}{1+x^4} dx + \int_{C_R} \frac{1}{1+z^4} dz \right]$$

On  $C_R$ , we have that  $|z| = R$ , so  $|1+z^4| \geq \left| |1| - |z|^4 \right| = R^4 - 1$ , and therefore

$$\begin{aligned} \left| \int_{C_R} \frac{1}{1+z^4} dz \right| &\leq \int_{C_R} \left| \frac{1}{1+z^4} \right| dz \\ &\leq \int_{C_R} \frac{1}{R^4 - 1} dz \\ &= \frac{1}{R^4 - 1} \int_{C_R} |dz| \\ &= \frac{1}{R^4 - 1} \cdot \pi R \end{aligned}$$

As  $R \rightarrow \infty$ , we have  $\int_{C_R} \frac{1}{1+z^4} dz \rightarrow 0$ , since it is bounded above by  $\frac{\pi R}{R^4-1}$  that goes to 0.

Therefore, taking the limit of LHS (as well as RHS) as  $R \rightarrow \infty$  in Equation (24.1), we have

$$\frac{1}{2\pi i} \int_{-\infty}^{\infty} \frac{1}{1+x^4} = \operatorname{Res} f(z) \Big|_{z=\alpha_1} + \operatorname{Res} f(z) \Big|_{z=\alpha_2}$$

Next, we compute the residues:

$$\begin{aligned} \operatorname{Res} f(z) \Big|_{z=\alpha_1} &= \lim_{z \rightarrow \alpha_1} f(z)(z - \alpha_1) \\ &= \lim_{z \rightarrow \alpha_1} \frac{z - \alpha_1}{g(z)} \quad \text{where } g(z) = 1 + z^4 \\ &= \lim_{z \rightarrow \alpha_1} \frac{z - \alpha_1}{g(z) - g(\alpha_1)} \quad \because g(\alpha_1) = 0 \\ &= \frac{1}{g'(z)} \Big|_{z=\alpha_1} = \frac{1}{4z^3} \Big|_{\alpha_1} = \frac{1}{4\alpha_1^3} \\ \operatorname{Res} f(z) \Big|_{z=\alpha_2} &= \frac{1}{4z^3} \Big|_{\alpha_2} = \frac{1}{4\alpha_2^3} \end{aligned}$$

So RHS of Equation (24.1) is

$$\text{RHS} = \frac{1}{4} \left( \frac{1}{e^{3i\frac{\pi}{4}}} + \frac{1}{e^{i\frac{\pi}{4}}} \right) = \frac{1}{4} \left( e^{-i\frac{3\pi}{4}} + e^{i\frac{\pi}{4}} \right) = \frac{i}{2} \sin \frac{\pi}{4} = -\frac{i}{2\sqrt{2}}$$

Therefore,

$$\int_{-\infty}^{\infty} \frac{1}{1+x^4} dx = 2\pi i \left( -\frac{i}{2\sqrt{2}} \right) = \frac{\pi}{2}$$

### Exercise 24.1.2

Show that  $\int_{-\infty}^{\infty} \frac{\sin x}{x} dx = \pi$

(Note: This integrand is not absolutely convergent)

If we try  $f(z) = \frac{\sin z}{z}$  on some semi-circle arc  $C_R$  with  $|f(z)| \leq \frac{1}{R}$ , then

$$\left| \int_{C_R} f(z) dz \right| \leq \int_{C_R} \frac{1}{R} |dz| = \frac{\text{length of } C_R}{R} \approx \pi$$

which means that the **decay** of the  $f$  is insufficient to help us compute our desired result.

Consider  $\sin x = \frac{e^{ix} - e^{-ix}}{2i}$ . We then need to show

$$I = \int_{-\infty}^{\infty} \frac{e^{ix} - e^{-ix}}{2ix} dx = \pi$$



By A4Q4, on  $C_\varepsilon$ , as  $\varepsilon \rightarrow 0$ , we pick up half of the residue at  $z = 0$ , i.e.

$$\frac{1}{2\pi i} \int_{C_\varepsilon} \frac{e^{iz}}{z} dz = -\frac{1}{2},$$

in which we note that the value is negative since  $C_\varepsilon$  is clockwise.

Therefore,

$$\lim_{\substack{R \rightarrow \infty \\ \varepsilon \rightarrow 0}} \left[ \int_{-R}^{-\varepsilon} \frac{e^{ix}}{x} dx + \int_{\varepsilon}^R \frac{e^{ix}}{x} dx \right] = \int_{-\infty}^{\infty} \frac{e^{ix}}{x} dx = \pi i$$

Using a similar argument, it can be shown that

$$\int_{-\infty}^{\infty} \frac{e^{-ix}}{x} dx = -\pi i$$

And with that, we obtain the final solution of

$$\frac{\pi i - (-\pi i)}{2i} = \pi$$

as required.

Refer to Stein & Shakarchi, Section 2.1, for **more examples**.

Work out the similar case as an exercise

**Exercise 24.1.3**

Show that

$$\int_{-\infty}^{\infty} \frac{e^{-ix}}{x} dx = -\pi i$$

INTERESTING EXAMPLES from Stein & Shakarchi

**Example 24.1.1**

Prove that for  $0 < a < 1$ ,

$$\int_{-\infty}^{\infty} \frac{e^{ax}}{1 + e^x} dx = \frac{\pi}{\sin \pi a}$$

Choose  $f(z) = \frac{e^{az}}{1 + e^z}$ . Note that  $f$  has one pole at  $z = i\pi$ . Consider a rectangle lying on the upper-half side of the plane with its base lying on the real axis and its top the line  $2\pi$ .

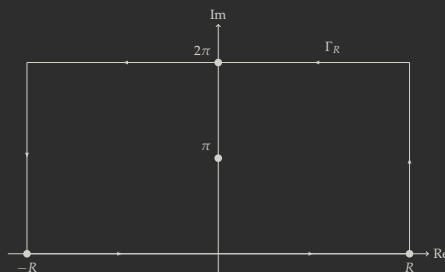

Figure 24.2: Contour  $\Gamma_R$

By the Residue Theorem, we have that

$$\frac{1}{2\pi i} \int_{\Gamma_R} f(z) dz = \operatorname{Res} f(z)$$

To evaluate the residue, note that

$$(z - i\pi) \cdot \frac{e^{az}}{1 + e^z} = e^{az} \cdot \frac{z - i\pi}{e^z - e^{i\pi}}$$

and  $\lim_{z \rightarrow i\pi} \frac{z - i\pi}{e^z - e^{i\pi}}$  is the inverse of the difference quotient (of first principles), and is hence  $e^{i\pi} = -1$ . Therefore

$$\operatorname{Res} f(z) = \lim_{z \rightarrow i\pi} (z - i\pi) \cdot \frac{e^{az}}{1 + e^z} = - \lim_{z \rightarrow i\pi} e^{az} = -e^{ai\pi}.$$

Let  $I$  be the desired integral and

$$I_R := \int_{-R}^R f(z) dz$$

so that we may have  $I_R \rightarrow I$  as  $R \rightarrow \infty$ . This will describe the bottom part of the rectangle. For the top part of the integral, notice that it is simply

$$\begin{aligned} \int_R^{-R} \frac{e^{az}}{1 + e^z} dz &= - \int_{-R}^R \frac{e^{a(x+2\pi i)}}{1 + e^{x+2\pi i}} dx \\ &= - \int_{-R}^R \frac{e^{ax} e^{2\pi ia}}{1 + e^x e^{2\pi i}} dx \\ &= -e^{2\pi ia} \int_{-R}^R \frac{e^{ax}}{1 + e^x} dx \quad \because e^{2\pi i} = 1 \\ &= -e^{2\pi ia} I_R. \end{aligned}$$

Let  $\gamma_r$  parameterize the vertical path on the right side of the rectangle, i.e.  $\gamma_r : [0, 2\pi] \rightarrow \mathbb{C}$  such that  $\gamma_r(t) = R + it$ . Then

$$\begin{aligned} \left| \int_{\gamma_r} \frac{e^{az}}{1 + e^z} dz \right| &= \left| \int_0^{2\pi} \frac{e^{a(R+ti)}}{1 + e^{R+ti}} dt \right| \\ &\leq \frac{e^{aR}}{1 + e^R} \int_0^{2\pi} dt \end{aligned}$$

which goes to 0 as  $R \rightarrow \infty$  since  $aR < R$  for  $0 < a < 1$ . Thus the integral of the vertical path evaluates to 0. We can perform a similar procedure for the path on the left and end up with the same result.

With that, we have that

$$I_R - e^{2\pi ia} I_R = -2\pi i e^{\pi ia}$$



## 25 Lecture 25 Mar 16 2018

We are now in a position to look into how we can define “logarithms” for  $\mathbb{C}$ .

### 25.1 The Argument Principle

Since we may express  $z = Re^{i(\theta+2k\pi)}$  for some  $k \in \mathbb{Z}$ , we would expect a logarithm to be of the form

$$\log z = \log R + i(\theta + 2k\pi)$$

So in general,

$$\log f(z) = \log |f(z)| + i \arg f(z)$$

The derivative of  $\log z$  is  $\frac{f'(z)}{f(z)}$ , should we expect the same idea extending from the reals, which is single-valued. Then the integral

$$\int_{\gamma} \frac{f'(z)}{f(z)} dz$$

can be interpreted as the change in the argument of  $f$  as  $z$  traverses the curve  $\gamma$ . Moreover, assuming that  $\gamma$  is a closed path, this change of argument is determined entirely by the zeros and poles of  $f$  in  $\gamma$ .

---

#### “ Note (Stein & Shakarchi, pg. 89)

The additivity formula for  $\log$ ,

$$\log(f_1 f_2) = \log f_1 + \log f_2$$

fails in general.

---

---

### Theorem 32 (Argument Principle)

Suppose  $f$  is meromorphic on a region (open & connected)  $\Omega \subseteq \mathbb{C}$ ,  $\gamma$  a closed path such that  $\gamma^* \in \Omega \setminus (\mathcal{A} \cup Z(f))$  such that

- $\forall w \notin \Omega \quad \text{Ind}_\gamma(w) = 0$
- $\forall w \in \Omega \setminus \gamma^* \quad \text{Ind}_\gamma(w) = 0 \text{ or } 1$

Then

$$\frac{1}{2\pi i} \int_\gamma \frac{f'(z)}{f(z)} dz = |Z(f) \cap \gamma^0| - |\mathcal{A} \cap \gamma^0|$$

where the zeros and poles are counted by multiplicity.

### Proof

(include proof here: use  Theorem 31 to CTP).

### Example 25.1.1

What are the poles of  $\frac{f'}{f}$ ?

Suppose that  $f$  has a zero of order  $k$  at  $z_0$ . Then  $\exists r > 0, \forall z \in D(z_0, r), f(z) = (z - z_0)^k g(z)$  where  $g \in H(D(z_0, r))$  and  $g \not\equiv 0$  on  $D(z_0, r)$ . So

$$\begin{aligned} f'(z) &= k(z - z_0)^{k-1} g(z) + (z - z_0)^k g'(z) \implies \\ \frac{f'(z)}{f(z)} &= \frac{k}{z - z_0} + \frac{g'(z)}{g(z)} \implies \end{aligned}$$

$\frac{f'}{f}$  has a simple pole at  $z_0$  with residue  $k$ .

Suppose  $f$  has a pole of order  $k$ . Then  $\exists r > 0, \forall z \in D(z_0, r), \exists h \in H(D(z_0, r))$   $h \not\equiv 0, f(z) = (z - z_0)^{-k} h(z)$ . Then

$$\begin{aligned} f'(z) &= -k(z - z_0)^{-k-1} h(z) + (z - z_0)^{-k} h'(z) \implies \\ \frac{f'(z)}{f(z)} &= \frac{-k}{z - z_0} + \frac{h'(z)}{h(z)} \implies \end{aligned}$$

$\frac{f'}{f}$  has a simple pole at  $z_0$  with residue  $-k$ .

$\therefore f$  is meromorphic on  $\Omega \implies \frac{f'}{f}$  has simple zeros and poles at exactly the zeros and poles of  $f$  with residue equals to the order of zeros of  $f$  and negative of the order of poles of  $f$ , respectively.



---

**▣ Theorem 33 (Rouché's Theorem)**

Let  $\Omega \subseteq \mathbb{C}$  be a region,  $f, g \in H(\Omega)$ ,  $\gamma$  a closed path on  $\Omega$  with

- $\forall w \notin \Omega \quad \text{Ind}_\gamma(w) = 0$ ,
- $\forall w \in \Omega \setminus \gamma^* \quad \text{Ind}_\gamma(w) = 0$  or  $1$ .

If  $f, g$  satisfy

$$\forall z \in \gamma^* \quad |f(z) - g(z)| < |f(z)|,$$

then  $f$  and  $g$  have the same number of zeros on  $\gamma^*$  (counted with multiplicity).

---

**✎ Proof (Idea)**

**WTS**  $\frac{1}{2\pi i} \int_\gamma \frac{f'}{f} = \frac{1}{2\pi i} \int_\gamma \frac{g'}{g}$ , since the result would follow by **▣** Theorem 32.

This is equivalent to  $\frac{1}{2\pi i} \int_\gamma \left[ \frac{f'}{f} - \frac{g'}{g} \right] = 0$ . By our small argument about how a log function should behave in  $\mathbb{C}$ , observe that we thus have

$$(\log f)' - (\log g)' = \left( \log \frac{f}{g} \right)'$$

So we wish to get either  $\frac{g}{f}$  or  $\frac{f}{g}$ .

---

**✎ Proof**

Given that  $\forall z \in \gamma^*, |f - g| < |f|$ . Note that  $f \not\equiv 0$ ; otherwise we would have the impossible case of  $|0 - g| < |0|$ .

Divide both sides by  $|f|$ , then

$$\forall z \in \gamma^* \quad \left| 1 - \frac{g}{f} \right| < 1$$

Therefore,  $\forall z \in \gamma^*, F = \frac{g}{f} \in B(1, 1)$ . Let  $\gamma : [a, b] \rightarrow \mathbb{C}$  be a parameterization of  $\gamma^*$ . Consider the function  $F \circ \gamma$ , which is a closed path that is contained in  $B(1, 1)$ .  $\therefore z = 0$  lies outside of  $F \circ \gamma$ , we have



## 26 Lecture 26 Mar 19 2018

### 26.1 The Argument Principle (Continued)

#### “ Note (Notation)

Let  $f$  be a function meromorphic on a region  $\Omega \subseteq \mathbb{C}$ . We write

$$\begin{aligned} N_f &:= \#\text{zeros of } f \text{ inside } \gamma^* - \#\text{poles of } f \text{ inside } \gamma^* \\ &= |Z(f) \cap \gamma^0| - |P(f) \cap \gamma^0| \end{aligned}$$

#### Remark

If all conditions of Rouché's Theorem hold except that, instead,  $f$  &  $g$  are meromorphic on  $\Omega$ , then if  $\gamma^*$  contains no poles of  $f$  &  $g$  then we can conclude that  $N_f = N_g$

#### Exercise 26.1.1

Find the number of roots of  $P(z) = z^8 - 5z^3 + z - 2$  lying in  $|z| \leq 1$ .

#### Solution

Let  $\gamma$  be the circle  $|z| = 1$ , oriented anticlockwise. Let  $g(z) = P(z)$ ,  $f(z) = -5z^3$ . Then  $|f(z)| = |5z^3| = 5$ , and

<sup>1</sup>We pick the dominant term in  $P$  for  $f$

$$\begin{aligned} |f(z) - g(z)| &= |z^8 + z - 2| \\ &\leq 1 + 1 + 2 \text{ by Triangle Inequality, and on } \gamma \\ &= 4 < 5 = |f(z)| \end{aligned}$$

So the inequality in Rouché's Theorem holds. Hence by Rouché,  $P(z) = g(z)$  has 3 roots (at  $z = 0$ , counted thrice since it has order 3) in  $|z| < 1$ .

To get the zeros for  $|z| \leq 1$ , change  $\gamma$  to be on  $|z| = 1 + \varepsilon$  for some  $\varepsilon > 0$

and proceed from there.

**You should try more of these problems from the recommended texts.**

### 26.1.1 Alternative Proof for FTA

Before proceeding with providing with alternative proof, note the following two definitions about polynomials.

---

#### Definition 29 (Monic Polynomial)

A monic polynomial is a polynomial with a leading coefficient of 1.

---



---

#### Definition 30 (Monomial)

A monomial is a polynomial with only one term.

---

Recall the statement of the Fundamental Theorem of Algebra (FTA)

$\forall P \in \mathbb{C}[z]$  with  $\deg P = n$  for some  $n \in \mathbb{N}$ ,  $P$  has  $n$  roots in  $\mathbb{C}$ .

---

#### Proof

Without loss of generality, assume that the polynomial is monic (divide the polynomial by the leading coefficient if necessary). Take

$$g(z) = z^n + a_{n-1}z^{n-1} + \dots + a_1z + a_0$$

with  $a_i \in \mathbb{C}$  for  $i \in [1, n-1] \subset \mathbb{N}$ . Let  $\gamma$  be the circle  $|z| = R > \max \left\{ \sum_{j=0}^{n-1} |a_j|, 1 \right\}^2$ , oriented anticlockwise. Let  $f(z) = z^n$ . Then  $|f(z)| = R^n$  on  $\gamma$ . We also have

$$\begin{aligned} |g(z) - f(z)| &= \left| a_{n-1}z^{n-1} + \dots + a_1z + a_0 \right| \\ &\leq |a_{n-1}| R^{n-1} + \dots + |a_1| R + |a_0| \\ &\leq (|a_{n-1}| + \dots + |a_1| + |a_0|) R^{n-1} \\ &< R^n \end{aligned}$$

<sup>2</sup> This is chosen from the later part of the proof

Hence, the inequality for Rouché's Theorem holds. Hence by Rouché,  $N_f = N_g$  and  $N_f = n$ .

**Exercise:** Show that these are the only zeros of  $g(z)$ , using factorization of polynomials in the ring  $\mathbb{C}[z]$ .

Suppose not, i.e. say  $g$  has  $m \neq n$  zeros. If  $m > n$ , then that would imply that  $\deg g = m$ , which is a contradiction. If  $m < n$ , then we can write

$$g(z) = (z - \alpha_1)(z - \alpha_2) \dots (z - \alpha_m)P_1(z)$$

where each  $\alpha_j \in \mathbb{C}$  is a root of  $g$  and  $P_1 \in \mathbb{C}[z]$  has  $\deg P_1 = n - m$  and that  $P_1$  has no roots (otherwise we would have  $m + 1$  roots). Then  $P_1$  must be a constant polynomial, but that would imply that  $\deg g = m \neq n$ , which is yet another contradiction.  $\square$

---

The above proof leads to the following result:

➤ **Corollary 34**

All the zeros of a monic polynomial lie inside the disc  $|z| \leq R$  with  $R = \max \left\{ \sum_{j=0}^{n-1} |a_j|, a \right\}$  where  $\{a_j\}_{j=0}^{n-1} \subset \mathbb{C}$  are the coefficients of the monic polynomial.

---

26.1.2 Open Mapping Theorem

📖 **Theorem 35 (Open Mapping Theorem)**

If  $f$  is holomorphic and non-constant in a region in  $\mathbb{C}$ , then  $f$  maps open sets to open sets.

✎ **Proof**

Let  $w_0 = f(z_0)$  for some  $z_0 \in \Omega \subseteq \mathbb{C}$ . Let  $d > 0$ .

**WTS**  $w_0 \in f(B(z_0, \delta))^0$ .

Let  $\gamma = \partial B(z_0, \delta)$  (i.e.  $|z - z_0| = \delta$ ), oriented anticlockwise.  $\forall z \in B(z_0, \delta)$ , let  $F(z) := f(z) - w_0$ . Then  $F$  has at least one zero inside  $\gamma$  (in particular,  $z_0$ ). Let  $G(z) := f(z) - w$  for some  $w \in f(B(z_0, \delta))$ .

**Want to have**  $G(z)$  having a zero inside  $\gamma$  for  $w$  “close enough” to  $w_0$ .

Our setup satisfies Rouché’s inequality:

$$\begin{aligned} \forall z \in \gamma^* \quad |F(z) - G(z)| &< |F(z)| \\ \text{or } |w - w_0| &< |f(z) - w_0| \text{ on } \gamma^* \end{aligned}$$

**We want**  $f(z) \neq w_0$  on  $\gamma$ . Now we can choose a  $\delta > 0$  such that  $B(z_0, \delta) \subseteq \Omega$  and  $\forall z \in \partial B(z_0, \delta)$ ,  $f(z) \neq w_0$ .

Let  $\varepsilon = \max_{z \in \gamma^*} |f(z) - w_0| > 0$ . Observe that

$$\begin{aligned} |w - w_0| < \varepsilon &\implies Z(G) \cap \gamma^0 \neq \emptyset \\ &\implies w \in f(B(z_0, \delta)) \\ &\implies w_0 \in f(B(z_0, \delta))^0 \end{aligned}$$

This completes the proof. □

---

## 27 Lecture 27 Mar 21 2018

### 27.1 Introductory Passage to Log Functions in $\mathbb{C}$

We have dealt with integrals of real numbers using our approach from complex analysis. But what would we do if we come across a problem of the form

$$\int_{-\infty}^{\infty} f(x)x^a dx \quad \text{for some } a \in \mathbb{R}?$$

If we try to apply residue integrals to the problem, we would need to consider  $f(z)z^a$ . But what is  $z^a$ , since  $a \in \mathbb{R}$  and not simply  $\in \mathbb{Z}$ !?

When  $a \in \mathbb{N}$ , we know that  $z^a = \underbrace{z \dots z}_{a \text{ times}}$ . When  $a \in \mathbb{R}$ , we want to be able to interpret  $z^a$  as  $e^{a \log z}$  just as we can do so in  $\mathbb{R}$ . This leads to the study of log functions as complex variables.

We shall try to approach the problem via **analytic continuation**.

#### Exercise 27.1.1 (A simple problem in analytic continuation)

Let  $f(z) = \sum_{n=0}^{\infty} z^n$  for  $|z| < 1$ . We want to **analytically continue**  $f$  onto  $\mathbb{C}$  if possible.

For  $|z| < 1$ , we know that  $\sum_{n=0}^{\infty} z^n = \frac{1}{1-z}$ . So let  $g(z) = \frac{1}{1-z}$ . Then we have that  $g \in H(\mathbb{C} \setminus \{1\})$ , where  $z = 1$  is a simple pole, and  $g$  agrees with  $f$  on  $|z| < 1$ .

$\therefore g$  is an analytic continuation of  $f$  to  $\mathbb{C} \setminus \{1\}$ , or we say that  $f$  can be analytically continued except at  $z = 1$ , which is a simple pole.

In real analysis,  $\log$  is the inverse of  $e^x$ . But on  $\mathbb{C}$ , the exponential function is not 1-1, e.g.

<sup>1</sup>  $e$  in  $\mathbb{R}$  is 1-1, and goes from  $\mathbb{R} \rightarrow \mathbb{R}^+$

$$e^z = 1 \iff z \in 2\pi i\mathbb{Z}$$

As such, we would like to restrict the domain (**why?**) for the exponential function. That begs the question: what is the natural domain on which  $\log z$  lives for  $z \in \mathbb{C}$ ?

- Globally, we would require the notion of **Riemann Surfaces**
- Locally, we would require the notion of **Simply Connected Domains**

(What does local and global mean here?)

## 27.2 Simply Connected Domains

### Definition 31 (Homotopy (Poincaré))

Let  $X$  be a topological space<sup>2</sup>. Recall that a curve in  $X$  is a continuous map  $\gamma : I \rightarrow X$  where  $I = [0, 1]$ , and  $\gamma$  is said to be closed if  $\gamma(0) = \gamma(1)$ .

<sup>2</sup> which we did not define

Two closed curves  $\gamma_0$  and  $\gamma_1$  are said to be **homotopic** if  $\exists H : I \times I \rightarrow X$  with

$$H(s, 0) = \gamma_0(s) \quad H(s, 1) = \gamma_1(s)$$

and  $H(s, t)$  be continuous with respect to  $s$  and  $t$ .

**Alternative Definition from Stein-Shakarchi - Complex Analysis**<sup>3</sup>

Let  $\gamma_0$  and  $\gamma_1$  be two curves in an open set  $\Omega$  with common endpoints. So if  $\gamma_0$  and  $\gamma_1$  are two parameterizations on  $[a, b]$ , then

$$\gamma_0(a) = \gamma_1(a) = \alpha \quad \text{and} \quad \gamma_0(b) = \gamma_1(b) = \beta$$

where  $\alpha, \beta \in \Omega$ . The two curves are said to be **homotopic** in  $\Omega$  if for each  $0 \leq s \leq 1$ ,  $\exists \gamma_s \subset \Omega$  parameterized by  $\gamma_s(t)$  defined on  $[a, b]$ , such that  $\forall s$ ,

$$\gamma_s(a) = \alpha \quad \text{and} \quad \gamma_s(b) = \beta,$$

and  $\forall t \in [a, b]$ ,

$$\gamma_s(t) \Big|_{s=0} = \gamma_0(t) \quad \text{and} \quad \gamma_s(t) \Big|_{s=1} = \gamma_1(t).$$

Moreover,  $\gamma_s(t)$  should be jointly continuous in  $s \in [0, 1]$  and  $t \in [a, b]$ .

<sup>3</sup> I preferred this definition cause it's easier to read, but I shall be using the definition from the lecture for the class itself unless stated otherwise



---

Loosely speaking,  $\gamma_0, \gamma_1$  are homotopic if we can **continuously deform**  $\gamma_0$  to  $\gamma_1$  (wlog) without any obstruction in  $X$ .

---

**Definition 32 (Simply Connected Domain)**

Let  $\Omega \subseteq \mathbb{C}$  be open. We say  $\Omega$  is **simply connected** if  $\Omega$  is connected, and  $\forall \gamma$  that is closed in  $\Omega$  is homotopic to a point (i.e. a constant map  $\gamma : I \rightarrow X$ ).

---

**Exercise 27.2.1**

1.  $\mathbb{C}$  is simply connected.
  2.  $\mathbb{C} \setminus \{z = x + iy : x \leq 0, y = 0\}$  is simply connected.
  3.  $\mathbb{C} \setminus \{0\}$  is not simply connected.
- 

**Note**

I will temporarily use  $\sim$  to represent homotopy, since it is an equivalence relation.

Here's a quick proof of that:

1. (Reflexive) Define  $H : I \times I \rightarrow X$ , where  $I = [a, b] \subseteq \mathbb{R}$ , with  $H(s, t) = \gamma_t(s)$ , where, in this case,  $t = 0$ . This shows reflexivity.
2. (Symmetric) Suppose  $\gamma_0 \sim \gamma_1$ . Then  $\exists H$  as above such that, this time,  $t \in [0, 1]$ . Choose  $G : I \times I \rightarrow X$  with  $G(s, t) = \gamma_{-t}(s)$  with  $t \in [0, 1]$ . Then  $\gamma_1 \sim \gamma_0$ .
3. (Transitive) Suppose  $\gamma_0 \sim \gamma_1$  and  $\gamma_1 \sim \gamma_2$ . Then  $\exists H_1, H_2 : I \times I \rightarrow X$ ,  $I$  as above, with

$$H_1(s, t) = \gamma_t(s)$$

$$H_2(s, q) = \gamma_q(s)$$

with  $t \in [0, 1]$  and  $q \in [1, 2]$ . Then we can simply create  $G : I \times I \rightarrow X$ , now with the 2nd argument, say,  $p \in [0, 2]$ . such that

$$G(s, p) = \begin{cases} H_1(s, p) = \gamma_p(s) & p \in [0, 1] \\ H_2(s, p) = \gamma_p(s) & p \in (1, 2] \end{cases}$$

Then  $\gamma_0 \sim \gamma_2$ .

One of the key facts about simply connected domains is that, if  $f \in H(\Omega)$ , then whenever  $\gamma_0 \sim \gamma_1$  in  $\Omega$

$$\int_{\gamma_0} f = \int_{\gamma_1} f$$

i.e. in a simply connected domain, the **integral does not depend on the chosen path**<sup>4</sup>.

<sup>4</sup> This should remind you of Goursat's Theorem and Cauchy's Theorem

---

## 28 Lecture 28 Mar 23 2018

### 28.1 Constructing Logarithm

#### Theorem 36 (Theorem 17)

Suppose  $\Omega$  is simply connected with  $0 \notin \Omega$ . Then in  $\Omega$ , we can define a function, call it  $\text{Log } z^1$ , such that

1.  $\text{Log } z \in H(\Omega) \wedge (\text{Log } z)' = \frac{1}{z}$
2.  $e^{\text{Log } z} = z$  for all  $z \in \Omega$
3.  $\forall r \in \mathbb{R}^+ [1, r] \subseteq \Omega \implies \text{Log } r - \text{Log } 1 = \log r$  where  $\log$  denotes the usual natural logarithm on  $\mathbb{R}^+$ .

<sup>1</sup> This is called a branch of the logarithm

#### Proof

1. The proof can be completed using the method used in proving Cauchy's Theorem for Convex Sets if we define  $\text{Log}$  as follows:

$$\forall z \in \Omega \exists w_0 \in \mathbb{C} e^{w_0} = z_0$$

(If we let  $z_0 = Re^{i\theta}$ , then we choose  $w_0 = \log R + i\theta$ ) Define

$$\text{Log } z = w_0 + \int_{z_0}^z \frac{1}{w} dw \quad (\dagger)$$

where the integral is over any path between the points  $z_0$  and  $z$  in  $\Omega$ . From here, use the proof provided in Cauchy's Theorem for Convex Sets to complete the proof.

2. Let  $G(z) = e^{-\text{Log } z} \cdot z$ . WTS  $G(z) = 1$ .

Note that by part 1,

$$\forall z \in \Omega \quad G'(z) = e^{-\text{Log } z} - z \cdot \frac{1}{z} \cdot e^{-\text{Log } z} = 0$$

$\therefore G' \equiv 0$  in  $\Omega$ .  $\therefore G \in H(\Omega)$ , we may write  $G$  as a power series, and since  $G' \equiv 0$  on  $\Omega$ , we have that  $G(z) = G(z_0)$  in a neighbourhood of a chosen center  $z_0 \in \Omega$ , say with radius  $r_0 > 0$ . Therefore

$$\exists c \in \mathbb{C} \quad \forall z \in B(z_0, r_0) \quad G(z) = c$$

Thus by *Analytic Continuation*, since  $\Omega$  is connected, we have that

$$\forall z \in \Omega, \quad G(z) = c.$$

It is therefore sufficient to show that  $G(z_0) = 1$ , and this is true by the following:

$$\begin{aligned} G(z_0) &= e^{-\text{Log } z_0} \cdot c_0 \\ &= e^{-w_0} \cdot z_0 \quad \because \text{Equation } (\dagger) \\ &= \frac{z_0}{e^{w_0}} = 1 \quad \because e^{w_0} = z_0 \end{aligned}$$

Thus we have  $G \equiv 1$  on  $\Omega$  and hence  $\forall z \in \Omega, e^{\text{Log } z} = z$ .

3. Suppose  $r \in \mathbb{R}^+$  and  $[1, r] \subseteq \Omega$ . By Equation  $(\dagger)$ ,

$$\begin{aligned} \text{Log } r &= w_0 + \frac{z-0}{r} \frac{1}{w} dw \\ &= w_0 + \int_{z_0}^1 \frac{1}{w} dw + \int_1^r \frac{1}{w} dw \\ &= \underbrace{w_0 + \int_{z_0}^1 \frac{1}{w} dw}_{\text{Log } 1 \text{ by Equation } (\dagger)} + \underbrace{\int_1^r \frac{1}{t} dt}_{\text{log } r - \text{log } 1 = \text{log } r} \end{aligned}$$

where we choose the straight line  $[1, r]$  as the path for the 3rd term in the last line. Therefore we have

$$\text{Log } r - \text{Log } 1 = \text{log } r$$

as required. □

### “ Note

If we choose  $z_0 = 1$  and  $w_0 = 0$ , then  $\text{Log } 1 = 0$ , and hence  $\text{Log } r = \text{log } r$  for any  $r \in \mathbb{R}^+$  with  $[1, r] \subseteq \Omega$ .

28.2 Branches of the Logarithm

1. **(Principal Branch)** Let  $\Omega_1 = \mathbb{C} \setminus (-\infty, 0]$ . We will write  $z \in \Omega_1$  as  $z = re^{i\theta}$  with  $r > 0$  and  $\theta \in (-\pi, \pi)$ . Pick  $z_0 = 1 \wedge w_0 = 0$ . By Equation (+),  $\text{Log } z = \int_1^z \frac{1}{w} dw$ . Then in this case,

$$\text{Log } z = \log r + i\theta \quad \text{when } z = re^{i\theta} \text{ with } \theta \in (-\pi, \pi)$$

To see this, pick the straight line path from 1 to  $r$ , and then any path from  $r$  to  $z = re^{i\theta}$

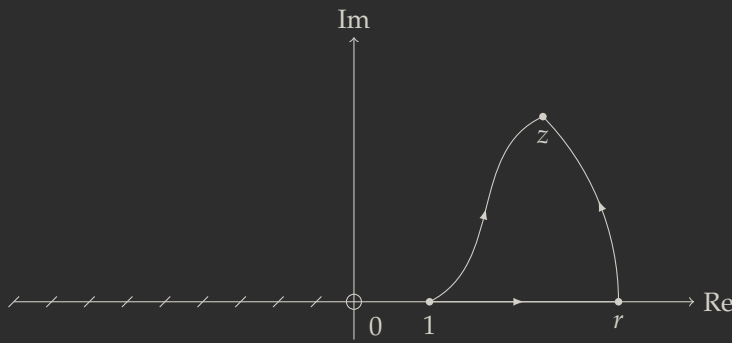

Then

$$\begin{aligned} \int_1^z \frac{1}{w} dw &= \int_1^r \frac{1}{t} dt + \int_0^\pi \frac{ire^{it}}{re^{it}} dt \\ &= \log r + i\theta \end{aligned}$$

**Exercise 28.2.1**

Let  $z_1 = e^{\frac{2\pi i}{3}}$ , then, using the Principal Branch,  $\text{Log } z_1 = i\frac{2\pi}{3}$ . But note that  $\text{Log}(z_1^2) \neq i\frac{4\pi}{3}$ . Instead, since

$$z_1^2 = e^{\frac{4\pi i}{3}} = e^{-\frac{2\pi i}{3}}$$

(∵ the region in consideration is  $(-\pi, \pi)$ ), we have that

$$\text{Log}(z_1^2) = -i\frac{2\pi}{3}$$

2. (a different branch) Let  $\Omega_2 = \mathbb{C} \setminus [0, \infty)$ . Write  $z \in \Omega_2$  as  $z = re^{i\theta}$  with  $r > 0 \wedge \theta \in (0, 2\pi)$ . Now we can pick **some function** so that

$$\text{Log } z = \log r + i\theta \quad \text{with } z = re^{i\theta} \wedge \theta \in (0, 2\pi)$$

In this case, we have that  $\text{Log}(z_1^2) = 2 \text{Log} z_1$  does hold.

With that established, we may now use  $z^a = e^{a \text{Log} z}$  if we fix a branch (and a simply connected domain) and stick with it till the end of the problem.

**Remark**

For the Principal Branch of the logarithm, the following Taylor expansion holds:

For  $|z| < 1$ ,

$$\begin{aligned} \log(1+z) &= z - \frac{z^2}{2} + \frac{z^3}{3} - \dots \\ &= \sum_{n=1}^{\infty} \frac{(-1)^{n+1} z^n}{n} \end{aligned}$$

(To remember this: note  $-\log(1-z) = \sum_{n=1}^{\infty} \frac{z^n}{n}$ ) Let

$$F(z) = -\log(1-z)$$

$$G(z) = \sum_{n=1}^{\infty} \frac{z^n}{n}.$$

It can be shown that for  $|z| < 1$ ,

$$F'(z) = \frac{1}{1-z} = G'(z)$$

which hence implies that

$$\begin{aligned} (F - G)' &\equiv 0 \\ \implies F - G &= c \quad \text{for some } c \in \mathbb{C} \end{aligned}$$

Plug in  $z = 0$  and we will get  $c = 0$ .

## 29 Lecture 29 Mar 26 2018

### 29.1 Examples for Analytic Continuation

#### Gamma Function

For  $s \in \mathbb{R}^+$ , we define

$$\Gamma(s) = \int_0^\infty e^{-t} t^s \frac{dt}{t}$$

where

$\int_0^\infty$  : the integral over a locally compact topological group  $\mathbb{R}^+$

$e^{-t}$  : additive character of  $\mathbb{R}^+$  (homomorphism from  $(\mathbb{R}^+, +)$  to  $\mathbb{R}$ )

$t^s$  : multiplicative character of  $\mathbb{R}^+$  (homomorphism from  $(\mathbb{R}^+, \cdot)$  to  $\mathbb{R}$ )

$\frac{dt}{t}$  : **Haar measure** for  $\mathbb{R}^+$  (invariant under multiplication)

#### Exercise 29.1.1

The integral  $\int_0^\infty e^{-t} t^s \frac{dt}{t}$  converges for  $s > 0$ . Prove this.

---

**“ Note (Euler)**

Euler observed that

$$\begin{aligned}
 \Gamma(n+1) &= \int_0^{\infty} e^{-t} t^{n+1} \frac{dt}{t} \\
 &= \int_0^{\infty} e^{-t} t^n dt \\
 &= -t^n e^{-t} \Big|_0^{\infty} + n \int_0^{\infty} e^{-t} t^{n-1} dt \quad \text{by IBP} \\
 &= n\Gamma(n) \\
 &\vdots \\
 &= n(n-1) \dots 2 \cdot 1 \cdot \Gamma(1)
 \end{aligned}$$

and since  $\Gamma(1) = \int_0^{\infty} e^{-t} dt = 1$ , we have that

$$\Gamma(n+1) = n!$$

**Remark**

Euler observed that  $\Gamma(s)$  is a continuous and differentiable function of  $s$  that interpolates the factorials.

We can extend  $\Gamma(s)$  to complex numbers  $s$  as follows:

$$\forall s \in \mathbb{C} \quad \operatorname{Re} s > 0 \quad \Gamma(s) = \int_0^{\infty} e^{-t} t^s \frac{dt}{t}$$

**“ Note**

1.  $\Gamma(s)$  is holomorphic for  $\operatorname{Re} s > 0$

- It can be shown that  $\int_0^{\infty} e^{-t} t^s \frac{dt}{t}$  converges for  $\operatorname{Re} s > 0$
- It can also show that this is  $\mathbb{C}$ -differentiable

2.  $\Gamma$  is a **Functional Equation**: We can repeat Euler's calculation to show that

$$\forall s \in \mathbb{C} \quad \operatorname{Re} s > 0 \quad \Gamma(s+1) = s\Gamma(s)$$

which implies that, if  $s \neq 0$ ,

$$\underbrace{\Gamma(s)}_{\text{defined for } \operatorname{Re} s > 0} = \frac{\Gamma(s+1)}{\underbrace{s}_{\text{defined for } \operatorname{Re} s > -1}}$$



because RHS makes sense for  $\operatorname{Re} s > -1$ , in which we may do

$$-1 < \operatorname{Re} s < 0 \implies 0 < \operatorname{Re}(s+1) < 1.$$

Thus, we can define, for  $-1 < \operatorname{Re} s < 0$ , that, if  $s \neq 0$ ,

$$\Gamma(s) = \frac{\Gamma(s+1)}{s}$$

It is noteworthy that this definition agrees with our original definition of  $\Gamma$  due to Equation (+).

Q: What happens at  $s = 0$ ?

Consider Equation (+), with  $s \rightarrow 0^+$ . Then

$$\lim_{s \rightarrow 0^+} [s\Gamma(s)] = \Gamma(1) = 0! = 1$$

$\therefore \Gamma(s)$  behaves like  $\frac{1}{s}$  near  $s = 0$ , i.e.  $\Gamma$  has a simple poles at  $s = 0$ .

Q: Can we continue the procedure above and go beyond  $\operatorname{Re} s > -1$ ?

Yes. Equation (+) holds for  $\Gamma(s+2)$  as well, which then we have, for  $\operatorname{Re} s > 0$ ,

$$\Gamma(s+2) = (s+1)\Gamma(s+1) = (s+1)(s)\Gamma(s)$$

And thus for  $\operatorname{Re} s > -2$  and  $s \neq 0, -1$ ,

$$\Gamma(s) = \frac{\Gamma(s+2)}{s(s+1)}$$

We can proceed with this procedure inductively so and analytically continue  $\Gamma$  to  $\mathbb{C} \setminus \{0, -1, -2, \dots\}$ .

## 29.2 Characterizing Logarithms

### Theorem 37 (Theorem 18)

Any entire function  $f(z)$  without any zeros has the form  $Ae^{g(z)}$  where  $g$  is some entire function and  $A \in \mathbb{C}$  is some constant.



## 30 Lecture 30 Mar 28 2018

### 30.1 Characterizing Logarithms

#### Theorem 38 (Theorem 18)

$\forall f$  that is entire with  $Z(f) = \emptyset$ ,

$$f(z) = Ae^{g(z)}$$

where  $g$  is some entire function and  $A \in \mathbb{C}$  is a constant.

#### Proof

Note

$$(f \in H(\mathbb{C}) \implies f' \in H(\mathbb{C}) \wedge Z(f) = \emptyset \implies \frac{f'}{f} \in H(\mathbb{C}))$$

Choose

$$g'(z) = \frac{f'(z)}{f(z)} = c_0 + c_1z + c_2z^2 + \dots$$

where  $\{c_j\}_{j \in \mathbb{Z}_{\geq 0}} \subseteq \mathbb{C}^1$ .

Consider  $F(z) = f(z)e^{-g(z)}$ . Then  $\forall z \in \mathbb{C}$ ,

$$\begin{aligned} F'(z) &= f'(z)e^{-g(z)} - f(z)g'(z)e^{-g(z)} \\ &= f'(z)e^{-g(z)} - f(z)\frac{f'(z)}{f(z)}e^{-g(z)} \\ &= 0 \end{aligned}$$

$\therefore \forall z \in \mathbb{C} \ F'(z) \equiv 0$ . Now because of that and  $F \in H(\mathbb{C})$ ,  $\exists A \in$

<sup>1</sup>  $g$  can be obtained by term-wise integration of the Taylor series for  $\frac{f'}{f}$

$$\mathbb{C} \quad \forall z \in \mathbb{C} \quad F(z) \equiv A^2.$$

$$\therefore \forall z \in \mathbb{C} \quad f(z) = Ae^{g(z)}.$$

<sup>2</sup>By considering the Taylor series for  $F$

□

This characterizes any function  $f$  that has  $Z(f) = \emptyset$ . Suppose  $f \in H(\mathbb{C})$  with  $\mathcal{A}_f = \{a_1, a_2, a_3, \dots\}$  for some  $\{a_j\}_{j \in \mathbb{N}} \subseteq \mathbb{C}$ . Construct some function  $h \in H(\mathbb{C})$  with zeros at exactly every point in  $\mathcal{A}_f$ . For example,

$$h(z) = \prod_{j=1}^{\infty} \left(1 - \frac{z}{a_j}\right)$$

is an entire function and has zeros at exactly  $\mathcal{A}_f$ . Then  $\frac{f}{h} \in H(\mathbb{C})$  with  $Z\left(\frac{f}{h}\right) = \emptyset$  on  $\mathbb{C}$ . Then by  Theorem 38,  $\exists g$ , some entire function, and  $A \in \mathbb{C}$  some constant, such that,

$$\frac{f}{h} = Ae^g \implies f(z) = Ah(z)e^{g(z)}$$

The construction of  $h$  motivates us to study our next topic: **infinite products**.

## 30.2 Infinite Products

### Definition 33 (Infinite Products)

Let  $u_1, u_2, \dots$  be a sequence in  $\mathbb{C}$ . Let

$$P_N = \prod_{j=1}^N (1 + u_j)$$

be the  $N^{\text{th}}$  **partial product**. If  $\lim_{N \rightarrow \infty} P_N$  exists, then we say that the **infinite product**,  $\prod_{j=1}^{\infty} (1 + u_j)$ , converges, and write

$$\lim_{N \rightarrow \infty} P_N = \prod_{j=1}^{\infty} (1 + u_j)$$

Before proceeding with an important result about infinite products, consider the following lemma.

**🌲 Lemma 39 (Bounds of the Partial Product)**

With  $\{u_j\}_{j=1}^{\infty}$  being a sequence in  $\mathbb{C}$ , let

$$P_N^* = \prod_{j=1}^N (1 + |u_j|).$$

Then

1.  $P_N^* \leq \exp\left(\sum_{j=1}^N |u_j|\right)$
2.  $\forall N \in \mathbb{N} \quad |P_N - 1| \leq P_N^* - 1$ <sup>3</sup>

<sup>3</sup>Note that  $P_N^* \geq 1$

**✎ Proof**

1. Note that  $\forall x > 0 \quad 1 + x \leq e^x$ . Thus

$$\begin{aligned} P_N^* &= \prod_{j=1}^N (1 + |u_j|) \\ &\leq \prod_{j=1}^N \exp(|u_j|) \\ &= \exp\left(\sum_{j=1}^N |u_j|\right) \end{aligned}$$

2. Using induction, note that  $N = 1$  holds since,

$$\begin{aligned} P_N - 1 &= 1 + u_1 - 1 = u_1 \\ P_N^* - 1 &= 1 + |u_1| - 1 = |u_1|. \end{aligned}$$

For  $N + 1$ , we have

$$\begin{aligned} |P_{N+1} - 1| &= |P_N(1 + u_{N+1}) - 1| \\ &= |P_N(1 + u_{N+1}) - (1 + u_{N+1}) + (1 + u_{N+1}) - 1| \\ &= |(P_N - 1)(1 + u_{N+1}) + u_{N+1}| \\ &\leq |P_N - 1| |1 + u_{N+1}| + |u_{N+1}| \quad \text{By Triangle Inequality} \\ &\leq (P_N^* - 1)(1 + |u_{N+1}|) + |u_{N+1}| \quad \text{By IH} \\ &= P_N^*(1 + |u_{N+1}|) - (1 + |u_{N+1}|) + |u_{N+1}| \\ &= P_{N+1}^* - 1 \end{aligned}$$

and the induction is complete. □

**Remark**

Lemma 39 continues to hold if  $P_N, P_N^*$  are replaced by

$$P_{N,M} = \prod_{j=M+1}^N (1 + u_j)$$

$$P_{N,M}^* = \prod_{j=M+1}^N (1 + |u_j|)$$

respectively, where  $N \geq M + 1$ .

**▣ Theorem 40 (Theorem 19)**

Suppose that  $\sum_{n=1}^{\infty} |u_n|$  converges. Then  $\prod_{n=1}^{\infty} (1 + u_n)$  converges. Moreover,  $\prod_{n=1}^{\infty} (1 + u_n)$  converges to zero iff  $u_{n_0} = -1$  for some  $n_0 \in \mathbb{N}$ .

**✎ Proof**

Let  $P_N = \prod_{n=1}^N (1 + u_n)$ .

*WTS*  $\{P_N\}$  is convergent. It suffices to show that  $\{P_N\}$  is Cauchy, i.e.<sup>4</sup>

$$\forall \varepsilon > 0 \exists N_0 > 0 \forall M, N > N_0 \quad |P_N - P_M| < \varepsilon$$

<sup>4</sup> Cauchy convergence from real analysis

$$\begin{aligned} |P_M - P_N| &= \left| P_N \left( \prod_{j=N+1}^M (1 + u_j) - 1 \right) \right| \\ &= |P_N| \left| \prod_{j=N+1}^M (1 + u_j) - 1 \right| \\ &\leq |P_N| \left| \prod_{j=N+1}^M (1 + |u_j|) - 1 \right| \quad \text{By 2 of Lemma 39} \\ &\leq |P_N| \left| \exp \left( \sum_{j=N+1}^M |u_j| \right) - 1 \right| \quad \text{By 1 of Lemma 39} \\ &\leq P_N^* \left( \exp \left( \sum_{j=N+1}^M |u_j| \right) - 1 \right). \end{aligned}$$

Thus  $\forall \varepsilon > 0, \because \sum_{j=1}^{\infty} |u_j| < \infty$  by assumption, we can choose an







## 31 Lecture 31 Apr 02 2018

### 31.1 Infinite Products (Continued)

#### Proof (Continued)

Note that in the earlier part of the proof, we showed that

$$|P_M - P_N| \leq |P_N| \left( \exp \left( \sum_{j=N+1}^M u_j \right) - 1 \right) \quad (31.1)$$

Notice that by the Reverse Triangle Inequality,

$$|P_M| = |P_M - P_N + P_N| \geq ||P_M - P_N| - |P_N||.$$

So for large enough  $M, N$ ,

$$|P_N - P_M| \leq |P_N| (e^\varepsilon - 1) \text{ by Equation (31.1) and the earlier part.}$$

Thus

$$\begin{aligned} |P_N| - |P_M - P_N| &\geq |P_N| (1 - (e^\varepsilon - 1)) \\ &= |P_N| (2 - e^\varepsilon). \end{aligned}$$

Therefore, for sufficiently large  $M, N$ ,

$$|P_M| \geq ||P_N| - |P_M - P_N|| \geq |P_N| (2 - e^\varepsilon) \quad (31.2)$$

Now to prove the iff statement: Suppose that the infinite product converges to 0. Let  $M \rightarrow \infty$  and fix  $N_0$  from above to be sufficiently large. Then for Equation (31.2), LHS  $\rightarrow 0$  as  $M \rightarrow \infty$ . Thus RHS  $\rightarrow 0$  as well, and we thus have that, in the limit,  $|P_{N_0}| (2 - e^\varepsilon) = 0$  and hence  $|P_{N_0}| = 0$ . But since  $P_{N_0}$  is a finite product, there must  $\exists n_0 \in \mathbb{N}$  such

that  $u_{n_0} = -1$ .

The converse is trivially true: suppose that  $\exists n_0 \in \mathbb{N}$  such that  $u_{n_0} = -1$ . Then we have that  $(1 - u_{n_0}) = 0$  and hence the product is 0.  $\square$

### Remark

To apply  Theorem 40 to a sequence of functions  $\{u_n(z)\}$  in some region  $\Omega \subseteq \mathbb{C}$ , we need  $\sum u_n(z)$  to converge absolutely and uniformly<sup>1</sup>.

<sup>1</sup> No dependence on  $z$ , which is part of the definition of **uniform convergence**.

### 31.1.1 Application to Riemann Zeta Function

We define  $\zeta(s) = \sum_{n=1}^{\infty} \frac{1}{n^s}$  for  $\text{Re}(s) > 1$ . This function is the well-known **Riemann Zeta Function**

### Remark

1. The series  $\sum_{n=1}^{\infty} \frac{1}{n^s}$  is absolutely convergent for  $\text{Re}(s) > 1$ .
2. By the construction of the function, it is holomorphic/analytic for  $\text{Re}(s) > 1$ <sup>2</sup>

<sup>2</sup> Requires the Weierstrass' M-test.

(HISTORY) Euler looked at the series with real numbers first. It was not until Riemann extended the function to become a function with complex variables that the series became well-known, and hence Riemann's name is prepended to the function instead of Euler.

THE SERIES can be analytically continued to the entire complex plane (using the functional equation<sup>3</sup>), except for a simple pole at  $s = 1$ , i.e.

$$\lim_{s \rightarrow 1^+} (1-s)\zeta(s) = 1.^4$$

<sup>3</sup> This is similar to what we did for the Gamma function.

<sup>4</sup> Cauchy's Residue Theorem

EULER SHOWED that for  $\text{Re}(s) > 1$ ,  $\sum_{n=1}^{\infty} \frac{1}{n^s} = \prod_{p \text{ prime}} (1 + \frac{1}{p^s} + \frac{1}{p^{2s}} + \dots)$ . Observe that RHS converges absolutely for  $\text{Re}(s) > 1$ . This identity is known as **Euler's Identity** and it is simply a statement about the unique factorization of integers into primes<sup>5</sup>.

<sup>5</sup> This is the **Fundamental Theorem of Arithmetic**

Note that for  $\operatorname{Re}(s) > 1$ , we can write

$$\begin{aligned}\zeta(s) &= \prod_{p \text{ prime}} \left( 1 + \frac{1}{p^s} + \frac{1}{p^{2s}} + \dots \right) \\ &= \prod_{p \text{ prime}} \left( \frac{1}{1 - \frac{1}{p^s}} \right) \quad (\text{Infinite Geometric Sum}) \\ &= \prod_{p \text{ prime}} \left( 1 - \frac{1}{p^s} \right)^{-1}\end{aligned}$$

This will be useful for the next statement.

---

✦ **Corollary 41 (Corollary for Theorem 19)**

$\zeta(s) \neq 0$  for  $\operatorname{Re}(s) > 1$ .

---

✏ **Proof**

Fix  $s$  with  $\operatorname{Re}(s) > 1$ . Then  $\zeta(s) = \prod_{n=1}^{\infty} (1 + u_n)$  with

$$u_n = \begin{cases} 0 & \text{if } n \neq p \text{ prime} \\ \frac{1}{p^s} + \frac{1}{p^{2s}} + \dots & \text{if } n = p \text{ prime} \end{cases}$$

For each  $s$ , we have that each of the sums  $\frac{1}{p^s} + \frac{1}{p^{2s}} + \dots$  converges absolutely for  $\operatorname{Re}(s) > 1$ . Also,  $\sum_{n=1}^{\infty} u_n$  converges absolutely and uniformly for  $\operatorname{Re}(s) > 1$ .<sup>6</sup>

Basically, we can apply  Theorem 40. So

$$\begin{aligned}\forall s \in \mathbf{C} \operatorname{Re}(s) > 1 \quad \zeta(s) = 0 &\iff \exists n \in \mathbf{N} \quad u_n = -1 \\ &\iff 1 + \frac{1}{p^s} + \frac{1}{p^{2s}} + \dots \text{ for } p \text{ prime} \\ &\iff \frac{p^s}{p^s - 1} \text{ by the Infinite Geometric Sum} \\ &\iff p^s = 0 \iff e^{s \log p} = 0 \\ &\not\iff \forall x \in \mathbb{R} e^x \neq 0.\end{aligned}$$

This completes the proof. □

---

<sup>6</sup> These two statements are not too hard to make reliable heuristics to make sense that they are true.



## 32 Lecture 32 Apr 04 2018

### 32.1 Infinite Products (Continued 2)

#### 32.1.1 Weierstrass Products

PROBLEM: Given a sequence  $\{a_n\}_{n \in \mathbb{N}} \subseteq \mathbb{C}$ , where  $\forall n \in \mathbb{N}, a_n \neq 0$ , construct an entire function  $f$  with zeros precisely at each of the  $a_n$ 's.

It is tempting to consider an infinite product such as  $\prod_{n=1}^{\infty} \left(1 - \frac{z}{a_n}\right)$ . But this may not converge all the time except for some specific sequence  $\{a_n\}$ .

The idea to approach this problem is to take the product of exponential factors so that it takes care of the convergence problem.

DEFINE:  $\forall n \in \mathbb{N}$

$$P_n(z) := z + \frac{z^2}{2} + \frac{z^3}{3} + \dots + \frac{z^n}{n}$$
$$E_n(z) := (1 - z) \exp(P_n(z))$$

and for  $n = 0$ , define

$$E_0(z) := 1 - z$$

OBSERVE that

- $E_n$  is entire and has a simple zero at exactly  $z = 1$ .
- $E_n(0) = 1$  and  $E_n(1) = 0$
- $P'_n(z) = 1 + z + z^2 + \dots + z^{n-1} = \frac{z^n - 1}{z - 1}$ <sup>1</sup>

<sup>1</sup> Finite geometric sum

---

 **Theorem 42 (Theorem 20)**

For  $|z| \leq 1$ ,  $|1 - E_n(z)| \leq |z|^{n+1}$ .

 **Proof**

Note that

$$\begin{aligned} E'_n(z) &= (1-z) \exp(P_n(z)) \cdot \left(\frac{z^n-1}{z-1}\right) - \exp(P_n(z)) \\ &= -z^n \exp(P_n(z)) \end{aligned}$$

and note that by the Taylor expansion of the exponent,

$$\exp(P_n(z)) = 1 + P_n(z) + \frac{(P_n(z))^2}{2!} + \dots$$

Since the power/Taylor expansion of  $P_n(z)$  has non-negative and real coefficients, so does  $\exp(P_n(z))$ . Therefore, we have

$$\begin{aligned} -E'_n(z) &= z^n \exp(P_n(z)) \\ &= z^n \cdot \sum_{m=0}^{\infty} a_m z^m \quad a_0 \neq 0^2, \forall m \in \mathbb{N} \quad a_m \geq 0 \\ &= \sum_{m=n}^{\infty} c_m z^m \quad c_0 \neq 0, \forall m > n \quad c_m \geq 0, \end{aligned} \quad (*)$$

which holds  $\forall z \in \mathbb{C}$  since  $E'_n$  is entire<sup>2</sup>.

<sup>2</sup> This is because the exponential function is non-zero.

<sup>3</sup> This is true by  Theorem 5, since  $E_n$  is entire.

Now note that

$$\begin{aligned} \int_0^z -E'_n(w) dw &= -E_n(z) + E_n(0) \text{ by FTC} \\ &= 1 - E_n(z). \end{aligned}$$

Also, by Equation (\*),

$$\int_0^z -E'_n(w) dw = \sum_{m=n}^{\infty} \frac{c_m}{m+1} z^{m+1}.$$

Therefore,

$$1 - E_n(z) = \sum_{m=n}^{\infty} \frac{c_m}{m+1} z^{m+1} = \frac{c_n}{n+1} z^{n+1} + \dots,$$

which implies that

$$\frac{1 - E_n(z)}{z^{n+1}} = \sum_{m=n}^{\infty} \frac{c_m}{m+1} z^{m-n} \quad \because c_n \neq 0$$

Let  $\phi_n(z) := \frac{1 - E_n(z)}{z^{n+1}} = \sum_{k=0}^{\infty} b_k z^k$ , where as defined, we have that  $b_0 \neq 0$  and  $\forall k \in \mathbb{N} \ b_k \geq 0$ . By the Triangle Inequality, and since  $|z| \leq 1$ , we have that

$$\begin{aligned} \left| \frac{1 - E_n(z)}{z^{n+1}} \right| &= \left| \sum_{k=0}^{\infty} b_k z^k \right| \leq \sum_{k=0}^{\infty} |b_k z^k| \leq \sum_{k=0}^{\infty} (|b_k| \cdot 1) \\ &= \sum_{k=0}^{\infty} b_k = \phi_n(1) = \frac{1 - E_n(1)}{1} = 1. \end{aligned}$$

Hence for  $|z| \leq 1$ , we have the desired inequality,

$$|1 - E_n(z)| \leq |z|^{n+1}$$

□

### Theorem 43 (Theorem 21)

Let  $\{a_n\}_{n \in \mathbb{N}} \subseteq \mathbb{C}$  with  $a_n \rightarrow \infty$  as  $n \rightarrow \infty$ , and  $\forall n \in \mathbb{N}, a_n \neq 0$ . Then the **Weierstrass Product**

$$f(z) = \prod_{n=1}^{\infty} E_n\left(\frac{z}{a_n}\right) \quad (32.1)$$

is entire and has zeros at exactly  $\{a_n\}$  and nowhere else.

### Proof

Let  $R > 0$  and  $\Omega = D(0, R) \subseteq \mathbb{C}$ . Let  $z \in \Omega$ .  $\because |a_n| \rightarrow \infty$ ,  $\exists N_0 > 0 \ \forall n \geq N_0 \ |a_n| \geq 2R$ . Note

$$\prod_{n=N_0}^{\infty} E_n\left(\frac{z}{a_n}\right) = \prod_{n=N_0}^{\infty} \left( 1 + \underbrace{\left( E_n\left(\frac{z}{a_n}\right) - 1 \right)}_{\text{call this } u_n(z)} \right)$$

On  $\Omega$ , since  $|z| \leq R \wedge \forall n \geq N_0 \ |a_n| \geq 2R$ , by  Theorem 42 we

have that  $\forall n \geq N_0 \wedge \forall z \in \Omega$ ,

$$\left| \frac{z}{a_n} \right| \leq 1 \implies \left| E_n \left( \frac{z}{a_n} \right) - 1 \right| \leq \left| \frac{z}{a_n} \right|^{n+1} \leq \frac{1}{2^{n+1}}$$

Then by  Theorem 40 and its remark, since  $\sum_{n=1}^{\infty} u_n(z)$  converges absolutely and uniformly on  $\Omega$ , the infinite product  $\prod_{n=N_0}^{\infty} (1 + u_n(z))$  converges.

**Exercise** To prove that the infinite product converges uniformly on  $\Omega$ , it suffices to show that it satisfies the Cauchy criterion: Define  $f_n := \sum_{j=n}^{\infty} (1 + u_j(z))$ . Note that for  $m > n \geq N_0$ ,

$$\begin{aligned} |f_m - f_n| &= \left| \sum_{j=n}^{m-1} (1 + u_j(z)) \right| \\ &\leq \left| \sum_{j=n}^{m-1} (1 + |u_j(z)|) \right| \text{ by 2 of Lemma 39} \\ &\leq \exp \sum_{j=n}^{m-1} |u_j(z)| \text{ by 1 of Lemma 39} \end{aligned}$$

So  $\forall \varepsilon > 0$ , since  $\sum_{j=1}^{\infty} |u_n(z)|$  converges,  $\exists N_0 > 0^4 \forall m > n \geq N_0$ , such that

$$\sum_{j=n}^{m-1} |u_n(z)| \leq \varepsilon$$

and hence

$$|f_m - f_n| \leq e^\varepsilon,$$

thus satisfying the Cauchy criterion and hence showing that the infinite product is uniformly convergent.

**Exercise** We now need to show that the infinite product is a holomorphic function on  $\Omega$ . Note that by construction of  $E_n$ , it has no poles, and is entire. Note that we have that the  $\{f_n\}_{n \in \mathbb{N}}$  is a sequence in  $\mathbb{C}$  that is uniformly convergent to the function  $f(z) = \prod_{n=1}^{\infty} E_n \left( \frac{z}{a_n} \right)$  in  $\Omega$ . Let  $D$  be any disc whose closure<sup>5</sup> is contained in  $\Omega$ , and  $T$  any triangle in  $D$ . Then by Goursat's Theorem,

$$\int_T f_n = 0.$$

Since  $\{f_n\}_{n \in \mathbb{N}}$  converges uniformly to  $f$ ,  $f$  is continuous<sup>6</sup> and

$$\int_T f_n \rightarrow \int_T f.$$

Thus  $\int_T f = 0$ . Then by Morera's Theorem, we have that  $f \in H(D)$  and

<sup>4</sup> choose an  $N_0$  different from the earlier  $N_0$  if necessary

A more complete statement and proof of this statement is available in Stein & Shakarchi's Complex Analysis (Chapter 2, Section 5.2, Theorem 5.2).

<sup>5</sup>  $\bar{D} := \{K \in \mathbb{C} : K \text{ closed} \wedge D \subseteq K\}$

<sup>6</sup> This is a relatively easy proof that can be done using techniques from Real Analysis.

**Exercise 32.1.1**

Prove that  $f$  is continuous under the supposition that  $\{f_n\}_{n \in \mathbb{N}}$  is uniformly convergent.



since  $D$  is arbitrary,  $f \in H(\Omega)$  as required.

Now since  $R$  is arbitrary, we have that  $f \in H(\mathbb{C})$ , i.e.  $f$  is entire.

To find the zeros of  $f$ , let  $z \in \Omega$ . By  Theorem 40 and in particular its remark, we have that

$$\prod_{j=N_0}^{\infty} E_j\left(\frac{z}{a_j}\right) = 0 \iff E_n\left(\frac{z}{a_n}\right) = 0 \text{ for some } n \geq N_0,$$

Therefore,

$$\prod_{j=1}^{\infty} E_N\left(\frac{z}{a_j}\right) = 0 \iff E_n\left(\frac{z}{a_n}\right) = 0 \iff z = a_n$$

for some  $n \in \mathbb{N}$ . This shows that

$$Z(f) = \{a_n\} \cap \Omega,$$

and since  $R > 0$  is arbitrary, we have that  $Z(f) = \{a_n : n \in \mathbb{N}\}$ . This completes the proof. □

### Example 32.1.1

Construct an entire function with simple zeros at  $z = 0, \pm 1, \pm 2, \dots$ , i.e.  $z \in \mathbb{Z}$ .

**SOLUTION 1:** Define  $f_1(z) = \prod_{n=1}^{\infty} E_n\left(\frac{z}{n}\right)$ , which is entire and has zeros at exactly  $\mathbb{N}$  by  Theorem 43, and  $f_2(z) = f_1(-z)$ , which would have zeros at  $-\mathbb{N}$ . Then simply choose the function

$$f(z) = z \cdot f_1(z) \cdot f_2(z)$$

so that we include the root  $z = 0$ .

**SOLUTION 2:** We can also choose

$$f(z) = z \cdot \prod_{n=1}^{\infty} \left(1 - \left(\frac{z}{n}\right)^2\right)$$

#### Exercise 32.1.2

Check that  $f$  indeed has its zeros at all integers.

Note that  $\sin(\pi z)$  is entire and has simple zeros at exactly  $z \in \mathbb{Z}$ . Then

$$\frac{\sin(\pi z)}{f(z)} \text{ has no zeros or poles } \forall z,$$



## 33 Index

- analytic, 91
- analytic continuation, 143
- argument, 23, 135
- Argument Principle, 10, 136
  
- boundary of  $C$ , 82
  
- Casorati-Weierstrass, 10, 115
- Cauchy's Integral Formula, 9, 82, 88
- Cauchy's Residue Theorem, 10, 120
- Cauchy's Residue Theorem - Generalized, 10, 123
- Cauchy's Theorem for Convex Set, 9, 81
- Cauchy-Riemann Equations, 9, 45
- closed, 72
- complex number, 11
- complex plane, 11
- conjugate of  $z$ , 14
- continuous, 39
- contour, 62
- converges, 37
- convex set, 81
  
- deMoivre's formula, 26
- deMoivre's Law, 26
- differentiable/holomorphic, 42
  
- entire, 56
- equivalent parameterizations, 61
- essential singularity, 109
- Euler's formula, 23
  
- Euler's Identity, 162
  
- Functional Equation, 152
- Fundamental Theorem of Algebra, 96, 140
- Fundamental Theorem of Arithmetic, 162
- Fundamental Theorem of Calculus, 9, 71
  
- Gamma Function, 151
- Goursat's Theorem, 9, 73
  
- Haar measure, 151
- homotopic, 144
- Homotopy, 8, 144
  
- imaginary part, 11
- infinite product, 156
- Infinite Products, 8, 156
- infinite products, 156
- interior, 73
  
- limit supremum, 51
  
- modulus, 15
- Monic Polynomial, 8, 140
- Monomial, 8, 140
- Morera's Theorem, 10, 101
- multiplicative inverse, 13
  
- neighbourhood, 42
  
- Open Mapping Theorem, 10, 141
  
- partial product, 156
- point/isolated singularity, 107
- pole, 109
- pole of order  $n$ , 113
- poles, 109
- power series, 49
- Principal Branch, 149
- principal part, 114
- Product Formula of Sine, 170
  
- radius of convergence, 51
- real part, 11
- removable singularities, 109
- removable singularity, 108, 111
- residue, 114
- Riemann Zeta Function, 162
- Rouché's Theorem, 10, 137
  
- simple zero, 112
- simply connected, 145
- Simply Connected Domain, 8, 145
  
- uniform convergence, 162
  
- Weierstrass Product, 167
- winding number, 82
- Winding Number Theorem, 10, 103
  
- zero of order  $n$ , 112